



# **Electric Scooter User Manual**

**for ZonDoo ZU08 Series**

(Please read the manual carefully before riding.)



# Contents

<b>1. Applicable Models</b>	1
<b>2. Product Overview</b>	1
<b>3. The Items Packed in Carton</b>	2
<b>4. How to Ride</b>	2
4.1 Folding and Unfolding	2
4.2 Charging	4
4.3 Riding Preparation and Turn-on	5
4.4 Riding	6
4.5 Safety Instructions and Legal Statement	6
4.6 Display Operation	9
<b>5. Maintenance and Warranty</b>	11
5.1 Cleaning	11
5.2 Storage	12
5.3 Maintenance	12
5.4 Warranty	13
<b>6. Contact Us</b>	17

## 1. Applicable Models

Model No.	Specification	Comments
ZU08	Height fixed stem and handle bar	Motor and battery capacity variable
ZU08 Pro	Height adjustable stem and foldable handle bar.	Motor and battery capacity variable

## 2. Product Overview

Take ZU08 PRO model as an example, the main parts are shown as below.

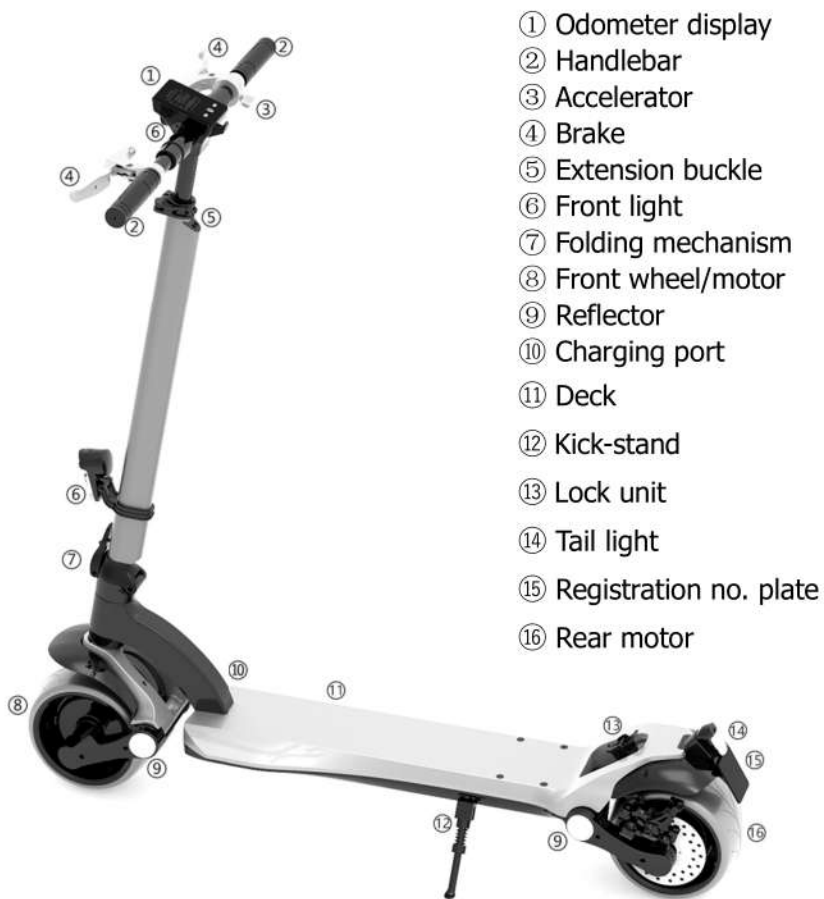

### 3. The Items Packed in Carton

<b>Item</b>	<b>Qty</b>	<b>Item</b>	<b>Qty</b>
Electric scooter	<b>1</b>	Charger	<b>1</b>
Tool kit	<b>1</b>	User manual	<b>1</b>

Some models may have saddle inside, please ask and confirm the packed details in the carton with ZonDoo sales team or local distributors before you purchase.

Please check the goods in the carton carefully before using.

To protect consumer legitimate rights and interests, please take pictures and videos when you find any problems/defectives with the products in the carton as soon as you receive it.



We consider the products inside the carton are in good condition and working properly if there is no pictures and videos shown the problems/defectives during carton opening process.

### 4. How to Ride

#### 4.1 Folding and Unfolding

Please check the folding process as below:

## Step 1: Lower the stem in the lowest position



### Step 1:

- ① Lower the handle bar to the lowest position (lowest height limits).

## Step 2: Fold down the handle bar

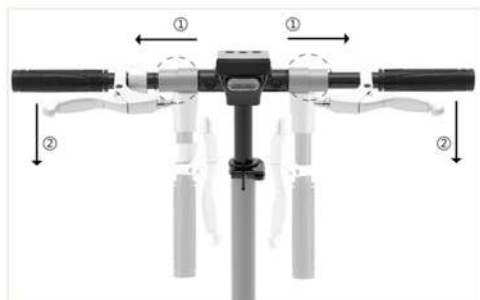

### Step 2:

- ① Grab the extension units of the handle bar and pull them out.
- ② Fold them down 90° from parallel to the vertical.

## Step 3: Fold down the stem



### Step 3:

- ① Open the folding mechanism of the stem.
- ② Fold the stem.

#### Step 4: Lock the stem

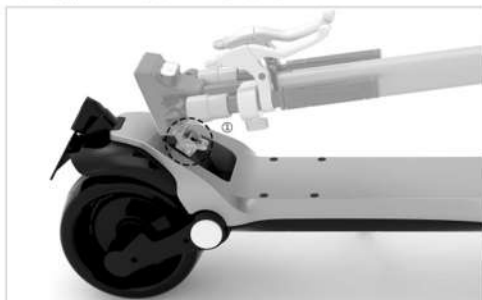

#### Step 4:

① Put the lock hook of the handle bar to the lock unit in the rear fender, then the stem will be folded and locked.

Unfolding is almost like doing the folding process in a reversed sequence. Push the lock unit to release the lock hook, unfold the stem in the vertical position, then close the folding mechanism to make the stem unfolded.

## 4.2 Charging



Open the charging port flap (as shown in the picture above) and plug in to charge.



#### Charging tips

- Please charge it fully (takes 6-8 hours) before your 1<sup>st</sup> riding.
- Please charge the scooter with correct power supply (200~240V/50-60Hz). Please keep children, pet or inflammables away from the scooter when it's charging.

- Do NOT charge when the plug/charging port/slot/socket is wet/humidity to avoid serious consequences because of electric spark and electric short-circuit.
- Please charge it once a month at least even if there's no riding.
- Please use the batteries, chargers and cables supplied by the original manufacturer and prevent the battery from being overcharged.
- Please do not use the charger if the charger cable has visual defectives, and check with ZonDoo to change/replace it immediately.
- Please do not repair the battery, charger or cable by yourself or the 3<sup>rd</sup> party without ZonDoo written approval.
- The scooter is prohibited to turn on, power-on and press throttle during charging.

#### 4.3 Riding Preparation and Turn-on

- Before riding, please check if all the parts of the scooter are installed firmly.
- Please wear safety helmets, gloves and knee/elbow pads before riding.
- Long press(3S) the power button (shown below P1) to power on the display, the scooter is ready for riding.





- Please check if all the parts are working well including but not limited to mechanical parts and electric parts like folding and lock mechanism,brakes,tire pressure,motor,controller and battery etc.

#### 4.4 Riding

- Step on the deck with one foot and kick with another on the ground,then pull the throttle slowly to speed up.If you have the scooter with a seat, sit on the seat first.
- Lean your body left slightly and turn the steering handle bar steadily when turning left, and vice versa.
- Release the accelerator and pull brake lever softly if you want to stop the scooter. The mechanical disc brake system and EABS work together to ensure excellent brake performance.

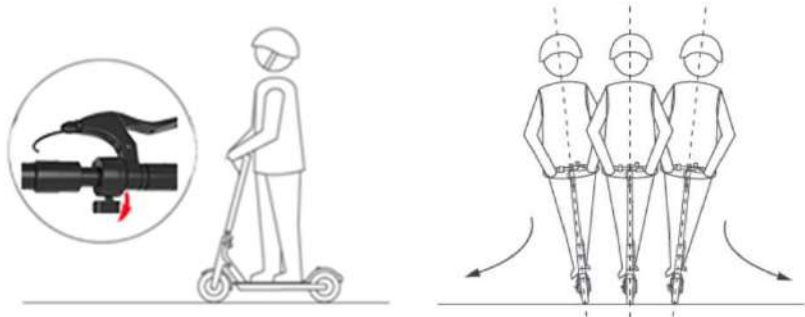

Please keep balance all the time during riding and do NOT jump off before the scooter is fully stopped.

NB. Please do NOT push the throttle sharply in the starting of scooter riding.

#### 4.5 Safety Instructions and Legal Statement

This clause contains important safety instructions to help you understand, use and maintain the scooter in correct ways. Riders must

fully understand all warnings, cautions and safety instructions and legal statement before riding.

- People without excellent balance, powerful muscle and good decision-making capability are not allowed to use this product.
- Never ride without helmet, knee/elbow pad and protection gloves.
- NEVER ride in rain, frozen terrain.
- NEVER ride in vehicle lane/free way, strictly follow the local transportation laws/directives and regulations.
- NEVER carry any passengers.
- NEVER turn on the scooter when it's charging.
- Do not press throttle when going downhill.
- Do not leave your hands off the handlebar while riding.
- Do not touch the brake disc and motor after riding, beware of burns.

### **NEVER ride electric scooters in below scenarios:**



NEVER ride in rain, frozen terrain.

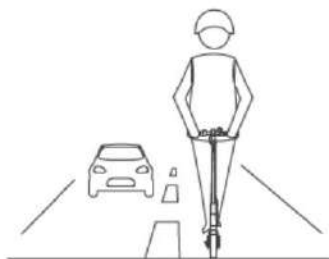

NEVER ride in vehicle lane/free way.



NEVER carry any passengers.



NEVER put hands off the handlebar.



NEVER ride in high speed in uneven terrain.

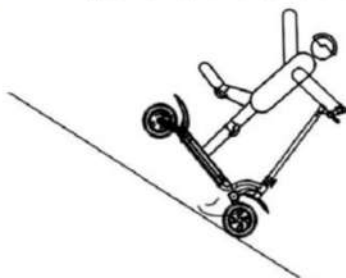

Do not press throttle when going downhill.

## Legal Statement

Riding the electric scooter may cause hazardous consequences even if you obey all the safety instructions. We assume no responsibility for any claim, liability or loss incurred by consumer's violation of the clauses in this user manual. If such things occur, we are NOT liable for any incidental damages or consequential damages due direct or indirect use of this product.

The rider by himself/herself shall undertake his/her responsibility for any unpredictable or inevitable risk during riding. RIDE AT YOUR OWN RISK.

## 4.6 Display Settings and Operation

- ① Lamp
- ② Cruise mode
- ③ Sports mode
- ④ Bluetooth
- ⑤ Speed
- ⑥ Mileage
- ⑦ Setting
- ⑧ Battery temperature
- ⑨ Error signals
- ⑩ Battery status



- Ⓐ Power On/Off
- Ⓑ Decrease gear level
- Ⓒ Increase gear level

### Display Settings

**POWER ON/OFF:** Long press Ⓐ to POWER ON/OFF

**Auto power off:** Automatic power off after 10 minutes without operation.

**Brakes:** Full disc brakes + electronic brakes. (tail lights highlight/flicker when braking).

**Lights:** When power on, short press Ⓐ, switch on upper headlight, double short press Ⓐ to switch on bottom headlight; tail light always on(or when the headlight is on) at low light.

**Gear switch:** Three gear levels, press (Ⓑ or Ⓒ) key to switch gear.

**Speed cruise:** When cruising mode is on, the scooter will drive in cruising speed when the rider keeps the constant speed about 10 seconds, and it'll unlock the cruising mode when you push the throttle or pull the brake.

### Debug Operation

**I,** Enter setup function: hold the Ⓑ Ⓒ keys at the same time for 5s. (enter setup settings interface)

**II,** Exit setting function: hold the Ⓑ Ⓒ keys at the same time for 5S to exit setting mode (no action, 15S to exit automatically)

**III,** In setting mode, the accelerator cannot drive the motor.

**IV,** After entering the setting, the speed bar will display P1. Press the power button to switch to P2, P3...

① P1:Speed unit switch: In P1 interface, short press Ⓒ key to change to mp/h, press Ⓑto change to km/h, and the default is km/h.

② P2:Switch between zero startup and non-zero startup: In P2 interface, short press Ⓑ to non-zero startup, press Ⓒ to zero startup, and default is none-zero start.

③ P3:Cruise function switch: In P3 interface, short press Ⓑ switch off the function, press Ⓒ to switch on, and the default is on.

<b>P code</b>	<b>Description</b>	<b>Default</b>
P1	Speed unit selection	KM/H
P2	Zero/none zero start selection	None zero start
P3	Cruising none cruising selection	Cruising mode



#### **P value settings comments:**

- P code varies sometimes because of ZonDoo products continuous optimization and upgrading.
- Please consult ZonDoo service team for debug if you have any query.

- Please keep all the P code value in default when riding.
- Please get written approval from ZonDoo service team before any change of P value, under condition that you are an experienced ZonDoo e-scooter rider.
- Please stop riding the e-scooter and consult ZonDoo service team immediately if you find any error code or error signals shown in the display.

<b>Error codes and trouble shooting</b>		
E.1 the throttle fault	E.2 Over voltage fault	E.3 Low-voltage fault
E.4 MOS tube failure	E.5 Hall line failure of motor	E.6 Locked-rotor fault
E.7 Operational failure	E.8 The brake failure	E.9 Communication failures

## **5. Maintenance and Warranty**

### **5.1 Cleaning**

Before cleaning, make sure the scooter is turned off, unplug the charger and close the charging port flap.

Please clean the scooter with soft rags, and please dry it after cleaning.

Do NOT use alcohol, gasoline and kerosene or other corrosive chemicals for

cleaning, and avoid high-pressure water sprayer washing.

## **5.2 Storage**

Avoid storing it in wet,direct sunlight conditions and car trunk.

Avoid putting the electric scooter in extreme environment with temperature higher than 50°C or lower than -20°,which will fatally and irreversibly damage the battery.

Please put the scooter indoor,dry and cool place if you do not ride it for long time.

## **5.3 Maintenance**

Regular maintenance is compulsory and necessary for the electric scooter to keep good condition, and the improper maintenance will cause permanent and irreversible damage to the scooter.

### **5.3.1 Battery Maintenance**

- Please use original battery pack and charging adapter from ZonDoo to avoid potential damage.
- Do NOT open or disassemble the battery pack to prevent potential damage to the battery.
- Keep the battery cable connectors away from metal or other electric conducts to avoid electric short circuit and dangerous situations.
- Please charge it before exhausting, and charge it in full after each riding to prolong the battery lifespan.
- Please fully charge it monthly to avoid battery dead even if you do not ride it for long time.The built-in intelligent chip will real-timely keep battery charge and discharge records.
- Please charge the scooter by using the original charger,and the maximum charging current is 2A(some models are even less),and the bigger charging current will damage the battery permanently and

irreversibly.

- Please strictly follow local regulations when disposing the scrapped batteries to protect the environment.
- Non-professionals are forbidden to disassemble the scooter, battery pack and controller etc, as it may cause electric shock, short circuit or even major safety accidents.

### **5.3.2 Other Maintenance**

- Before and after each riding, the rider must check and maintain scooter parts like all the bolts and nuts, brake systems, controller, throttle, motors and tires to make sure all the parts in good condition and working well.
- Please ask ZonDoo service team and local distributors to maintain, repair or replace them immediately if you find any parts are not working properly.



**Please contact ZonDoo service team/local distributors immediately if you find any problems/failures with your scooters.**

### **5.4 Warranty**

To protect consumer legitimate rights and interests, we provide you the global warranty based on following warranty terms. Please contact ZonDoo service team/local distributors immediately if you find any problems/failures with your scooters within warranty period.



### 5.4.1 Warranty Period

The warranty period of ZonDoo scooter are as below table if they are proven they are products problems.

S/N	Parts Description	Warranty Period
1	Frame, motor,controller	12 months
2	Battery,charger,mechanical brakes	6 months
3	Lights,throttles and some functional parts	1 months

**NB. Wearing parts and consumables are of no warranty.**



**The scooters or parts can not be covered by ZonDoo global warranty terms if the failures,damages and problems are caused by the below situations:**

- The scooters and parts are not properly stored/rided/operated/ maintained/repared /replaced as per the terms in "ZonDoo ZU08 Electric Scooter User Manual".
- The consumer's deliberate/accident violation of terms/clauses in this manual. And any electric parts repair or swap/scooter deck open/water in the deck will be regarded as user's violation of the user manual terms and conditions.

### 5.4.2 Warranty Card

Please fill in the "Warranty Card" and purchasing invoice when you ask ZonDoo service team/local distributors for warranty/after-sales service.

<b><u>Warranty Card</u></b>			
Dear customer, Thanks for choosing ZonDoo electric scooter. Please fill in the blanks below to secure ZonDoo after-sales services.			
Customer Info	Name		Work Place
	Telephone		
	Address		
Purchase Date		Motor S/N	
Model No.		VIN	
Invoice No.		Battery S/N	
Distributor Info.	Distributor Name		
	Contact		
Note.			



All the necessary pictures/videos shown the products/parts problems must be provided to ZonDoo service team as well.

Your personal information and data will be 100% protected and safe.



## 6. Contact Us

Please scan the below QR code for more service from ZonDoo.



ZonDoo service team: [support@zond-tech.com](mailto:support@zond-tech.com).

Official Website: <https://www.zond-tech.com>

Please feel free to contact us by email should you have any query about ZonDoo products/services. We will come back to you within 24hours.

CE RoHS FC MSDS UN38.3

