

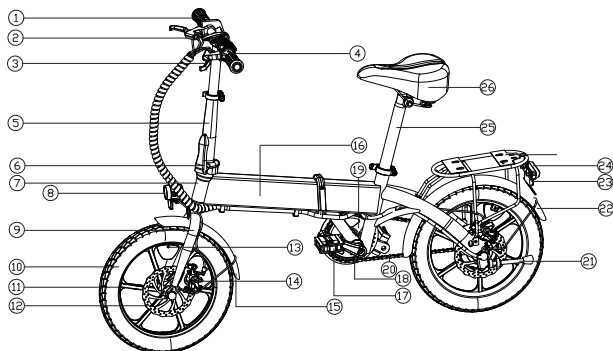

DYU SMART ELECTRIC BIKE A1F INSTRUCTION

Do not use the eBike without reading this manual carefully and
knowing your eBike thoroughly
Please save this manual for future reference

PARTS & COMPONENTS



- 01 Electric Shifter
- 02 Display
- 03 Brake Lever
- 04 Handlebar
- 05 Tube
- 06 Folding Handle
- 07 Head Tube
- 08 Front Light
- 09 Front Fork
- 10 Tire
- 11 Wheel Hub
- 12 Disc Brake Rotor
- 13 Front Wheel Reflector
- 14 Front Disc Brake Caliper
- 15 Mudguard
- 16 Frame
- 17 Pedal
- 18 Crank
- 19 Chain Hub
- 20 Chain
- 21 Kickstand
- 22 Rear Mudguard
- 23 Rear Reflector
- 24 Rear Light
- 25 Seat Tube
- 26 Saddle
- 27 Rear Rack

Note: As we upgrade our eBikes, the one you own may be slightly different from the one shown above, but how you use it will be the same.

In the Package



2× Pedals

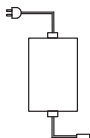

1× Charger



1× Owner's
Manual



1× Warranty
Card

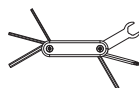

1× Multifunctional
Wrench

Battery Removal & Installment



1. Lower the seat to
the lowest position
and lock it



2. Fold the tube



3. Fold the frame

Installing the Pedals

Screw in the right pedal clockwise and the left counter-clockwise.

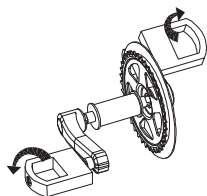

GETTING STARTED

1. After unpacking, align the handlebars, press down the quick-release handle, adjust the horizontal handlebar to the appropriate direction, and then tighten the horizontal handle quick-release. Squeeze the brake lever a few times lightly, and wait for the brake cable to return to its optimal state before use. Insert the Seatpost, adjust it to the appropriate height, and lock the quick-release handle. Install the pedals, and you're ready to go.
2. Charging: Connect the charger and start charging. When the charger indicator changes from red to yellow/green, continue charging for one more hour.
3. Power On/Off: Press the "M" button to power on.
4. Battery Level Indicator: The display has a five-level battery indicator. For more details, refer to the display function introduction.
5. Front Light: Long-press the "M" button to turn on.
6. Brakes and Tail Light: Electric acceleration cannot be applied when the brakes are not fully released. The tail light is powered separately and needs to be manually turned on.
7. Electric and Assistance Modes: The maximum electric speed is 15.5 mph (speed may vary based on load, road conditions, and battery status). You can cycle through three assistance levels; refer to the instrument panel function introduction for details. You can use the accelerator for electric propulsion in any mode.
8. Automatic Shutdown After 10 Minutes of Inactivity.
9. Battery Removal and Installation: The built-in battery is not removable. If you need to replace it, please get in touch with official customer support.

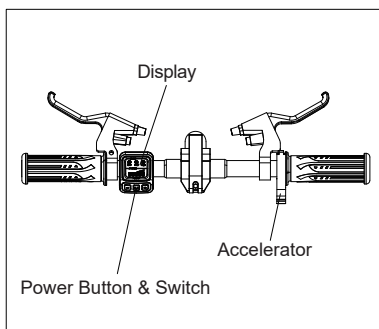
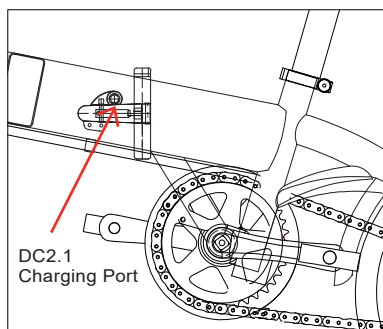

DISPLAY

Current battery level	<p>The diagram shows five battery level indicators. Each indicator is a square with a grid of dots. The first four are fully filled with dots, and the fifth is partially filled, with the top-right corner missing. To the right of these is a small triangle pointing right, indicating the battery level is increasing.</p>	Display the current battery level
-----------------------	--	-----------------------------------

SPECIFICATION

Build	Model	A1F Pro
	Body material	Iron frame
	Folded size	765*400*660 mm
	Expanded size	1342*542*1050 mm
	Packing size	775*410*570 mm
	Wheelbase	895 mm
	Pedal ground clearance	120 mm
	Wheel hub	40.6 cm
	Body color	Black
Performance	Weight	21.2 kg
	Max Load	75 kg
	Max speed	6 km/h
	Power consumption per hundred kilometers	1.1 kWh
	Range in throttle mode	30 km
	Range in pedal assist mode	60 km
	Hill climbing capacity	15 degrees
	Operating temperature	-10~45 degrees Celsius
	IP rating	IP54

SPECIFICATION

Core	Model	A1F Pro
	Battery type	Lithium-ion battery
	Battery capacity	7.5Ah
	Battery rated voltage	DC36V
	Charging voltage	DC42V
	Charger input voltage	AC240V
	Charging time	4 hours
	Motor type	Brushless DC motor
	Motor rated power	250W
	Motor rated voltage	36V
	Controller under voltage value	31±0.5V
	Controller over current value	15±1A
Features	Anti-theft Function	No
	APP Application	NO
	Headlight	Yes
	Rear light	Yes
	Adjustable seat height	Yes
	Cruise Control	NO
	Braking	Front and rear dual-disc brakes

Note:

The max speed may vary, depending on the battery level, load, tire pressure, terrain, lubrication state of the chain and bearings, etc. The ranges are determined upon tests at the ambient temperature of 25°C (or 77°F), at the speed of 15 to 20 km/h (or 9.32 to 12.43 mph), on smooth and firm terrain, with a load of 120 kg (or 264.55 lbs.), and within an uninterrupted period from full to zero battery level. The ranges may vary, depending on your riding behavior, ambient temperature, load, tire pressure, terrain, etc.

CIRCUIT DIAGRAM

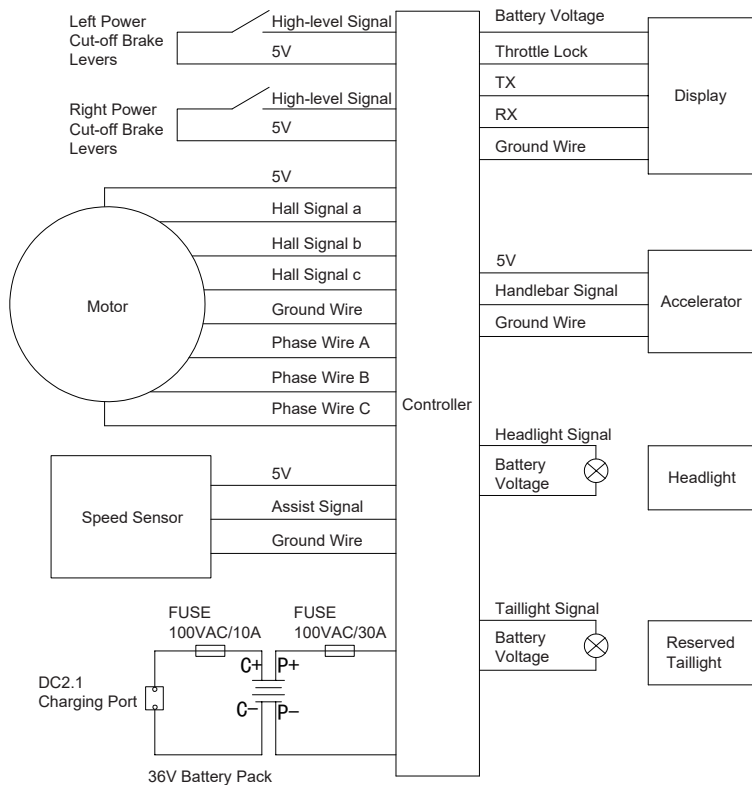

ATTENTION

Battery & Charging

- Do not connect the positive to negative, or vice versa. Do not damage, disassemble, or short-circuit the battery. Avoid water, other liquid, or other foreign matter inside the battery to prevent short circuit.
- Instructions in this manual must be followed when charging the battery, otherwise the owner shall take sole responsibility for any consequences.
- Charge the battery only at the temperature between 0°C (or 32°F) and 45°C (or 113°F), and discharge at the temperature between -20°C (or -4°F) and 60°C (or 140°F). The charging current should not exceed 2A. Charge only in a well-ventilated area, away from sun and heat.
- Use the original charger from the package to charge the battery. Connect the charger and battery before plugging the charger into the mains. Do not charge the battery for over 6 hours each time.
- When charging, if the charging indicator appears abnormal, a smell is released, or the charger overheats, stop charging immediately. Service or replace the charger.
- To stop charging, unplug from the mains before disconnecting the charger and battery.
- When the charging indicator turns green, stop charging.
- Do not leave the charger connected to any AC power source when not charging.
- When not in use, store the battery in a dry (relative humidity at 65±20%) and cool (temperature at 10-35°C, or 50-95°F) place. Keep away from fire, heat and high temperature. Do not put the battery in acid or alkaline liquid. Make sure to charge the battery for two hours each month.
- Before using the charger to charge a different battery, note the battery type and voltage that the charger may apply to.
- It is advisable not to carry the charger with your eBike. If you must, place the charger in a toolbox upon shock absorption treatment.
- Do not disassemble the charger or replace the parts and components in the charger on your own.
- Waste battery is classified as hazardous. Do not disassemble the waste battery on your own. It should be collected and recycled properly.

Riding your eBike

- Do not use the eBike before reading this manual carefully and knowing your eBike thoroughly.
- **This eBike is designed for riders aged 16-45. Anyone aged below 16 is strictly forbidden to ride this eBike.**
- **Please wear a helmet.**
- Do not lend your eBike to anyone who do not know how to use it, so as to avoid harm.
- When adjusting the steerer tube and seat tube, do not expose the minimum insertion marks.
- Before riding, check the tire pressure. It is advisable to maintain at 35-45 PSI.
- Before riding, ensure the power, lights, handles, brakes, wheels, reflectors and others are in good condition.
- Before carrying people or objects on your eBike, learn the local laws and regulations, and abide by them.
- Do not exceed the load capacity of 120 kg (or 264.60 lbs.).
- Wear a helmet, and obey traffic rules.
- Obey local traffic rules to keep to the right or left.
- Do not ride on any motorized lane or in any pedestrian crowd.

ATTENTION

- It is advisable not to go over 15 km/h (or 9.32 mph) when riding on any non-motorized lane, downhill, or paved road.
- Slow down in rain or snow as required braking distances increase.
- It is advisable not to ride in storms or any extreme weather.
- Avoid impact on the motor.
- Keep the bearings lubricated.
- Do not park your eBike in any lobby, walkway, evacuation stairway, or emergency entrance/exit.
- Do not charge or park your eBike inside any residential building. Keep away from combustibles when charging. Charging should not exceed 6 hours each time.

Maintenance

- The front and rear wheels should be aligned to the center of the front fork and frame.
- Park away from direct sunlight and rain.
- Do not rinse the eBike. Wipe with a damp cloth to clean.
- Check the motor and brakes frequently. Do not oil the braking system.
- Regularly check all screws and keep them fastened.
- Recommended torque specs: handlebar screw 60-80 kgf.cm (or 52.08-69.44 lbf.in), steering stem screw 175-200 kgf.cm (or 151.90-173.60 lbf.in), saddle screw 175-250 kgf.cm (or 151.90-217.00 lbf.in), and wheel screw 320-450 kgf.cm (or 277.70-390.60 lbf.in).
- Regularly check the tension of the chain, which can be adjusted via the chain regulator.
- Frequently check the tires for scratches, cracks or excessive wear. The inner tube and valve should be perpendicular to the wheel hub. Punctured, damaged or excessively worn inner tube and tire must be replaced immediately. Please contact professional technicians.
- It is forbidden to modify key structural parts including the frame, front fork and steerer tube, and any electrical parts. If damaged, replace with identical parts from our factory. Otherwise, the warranty shall be void and the owner shall take sole responsibility for any consequence.

Disclaimer

- Our company reserves the right to modify and give final interpretation to the product model, specification, and other information contained in this manual.
- The functions of the specific model referred to in this manual apply to this specific model only.
- The product model, specification, and other information contained in this manual is subject to any modification or change without notice.
- Without the prior written permission of the company, the contents of the manual may not be copied, modified, reprinted, disseminated or published in any form.
- Please read this manual carefully before using the product, and operate in accordance with the manual. Otherwise, the company shall not be liable for any personal or property damage, including damage to the product, caused by misuse or abuse.
- For more information, please visit our official website: www.dyucycle.com.



DYU Ebike Owners Group

Manufacturer: Shenzhen DYU Intelligent Mobility Technology Co., Ltd
Factory: DYU (Huizhou) Smart Transport Technology Co., Ltd.
Factory Address: Block 1, Factory 4, Sanxu Village Committee and Meihua Village Committee,
Luoyang Neighbourhood, Boluo County, Huizhou City, Guangdong Province
Telephone: 400-080-7170