

Dear users! Before enjoying a pleasant ride, make sure to carefully read the Owner's Manual, understand the relevant operation requirements, and properly store the Owner's Manual together with the accompanying product certificate. Do not use the electric bike until you have fully understood its performance!

Safety notes

Dear users,

The Owner's Manual describes the essential operation and maintenance methods of the electric bike. To enhance your riding experience, please consult this manual to familiarize yourself with the performance, features, safety notes, and maintenance needs of this product. If you have any questions, please contact the official after-sales team or local authorized service station in time. We will offer you diagnostic assistance as soon as possible.

Safety notes

1. Please ensure you comprehend and adhere to the safety notes outlined in this manual to significantly mitigate risk. Upon entering public spaces, please abide by all national and local laws and regulations. Remain vigilant while riding and maintain a safe distance from others and vehicles.
2. The electric bike must be operated according to the guidelines in the manual. The user will be responsible for any loss resulting from failure to follow the manual's guidelines.
3. According to the CE15194 standard, this product belongs to electrically power assisted cycles. You must continue to pedal to obtain power assistance. Under 6 km/h, you can use the push mode without pedaling; above 6 km/h, you must pedal to obtain the auxiliary output of the motor.
4. This product is not designed for professional off-road riding. Do not use it for off-road mountain biking, so as to avoid the risk of falling due to insufficient performance to support off-road riding.
5. For your initial ride, choose a private area free of traffic. Once you're comfortable with the product, you can venture onto public roads.
6. Before each ride, please ensure to thoroughly inspect for any loose fasteners or damaged parts. If this product makes abnormal sounds, please stop riding immediately and seek diagnostic support from the official after-sales team.
7. Avoid exceeding the speed limit. Never ride in areas where motor vehicles are present, regardless of the circumstances.
8. For safety reasons, users under the age of 16 are strictly prohibited from using this product. The use of this product is prohibited in the following situations:
 - Individuals under the influence of alcohol or drugs.
 - Individuals unable to participate in strenuous physical activities due to illness.
 - Individuals who are unable to maintain balance or who struggle with balance due to underdeveloped motor skills.
 - Individuals whose weights exceed the limit. (For the weight limit, see 2.1.1.)
 - Pregnant women.
8. Be careful when using this product in bad weather such as snow, rain, slippery roads, ice, etc. In these conditions, the braking distance may increase.
9. Do not attempt to charge this product if the charger or power supply is wet. When charging this product in a public area, ensure adherence to local safety laws and regulations.
10. In order to effectively protect and use your bicycle easily, please always use officially specified parts. Otherwise, unpredictable dangerous situations may occur due to incompatibility, especially for electronic parts such as batteries and motors.
11. If you want to modify your electric bike, please consult the official after-sales team and proceed with caution, ensuring adherence to local laws and regulations. The manufacturer assumes no liability for injuries or bicycle damage resulting from unauthorized modifications.(Changing any unofficial electrical components and non-standard mechanical parts such as chains/brakes, etc., will be considered unauthorized)
12. To minimize the risk of injury, please be sure to read and follow all prompts including "Caution", "Danger" and "Warning" in the Owner's Manual.

- **Danger:** Ignoring this warning could result in personal injury. To minimize harm to yourself and others. This notice specifies the actions you must take or avoid!
- **Warning:** Ignoring this warning could result in damage to the bike and its components. This notice specifies the actions you must take or avoid!
- **Caution:** Ignoring this warning could result in minor damage to the bike or impair its normal operation. This notice specifies the actions you should and should not take.

1. Introduction

- 1.1 Packing list
- 1.2 Components
- 1.3 Functions

2. Quick Guide

- 2.1 Installation guide
- 2.2 How to fold the bike
- 2.3 How to remove the battery
- 2.4 How to charge
- 2.5 Quick operation
- 2.6 Instrument setting

3. Notes For Maintenance

- 3.1 Notes for operation
- 3.2 Maintenance and self-inspection
- 3.3 Troubleshooting

4. Service Guide

- 4.1 After-sales service and warranty coverage
- 4.2 Warranty card and repair record
- 4.3 Product parameters



ENGWE
Technical
support video



ENGWE
Manual

1. Introduction

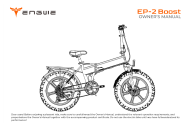
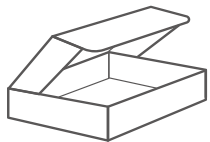

Manual



8-10 13-15 14-15

Wrench



Charger



M4 M5 M6

Screwdrivers



Screwdriver



Ties



Spare parts kit



Saddle



Foldable riser and stem

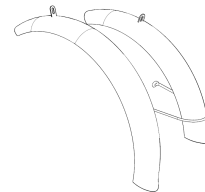

Mudguard x 2

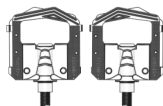

Foldable pedal x 2

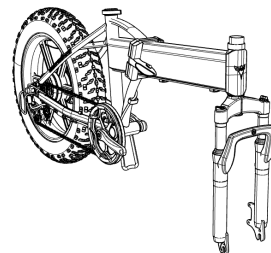

Frame body

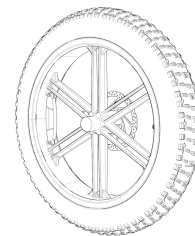

Front tire

1.1 Packing list

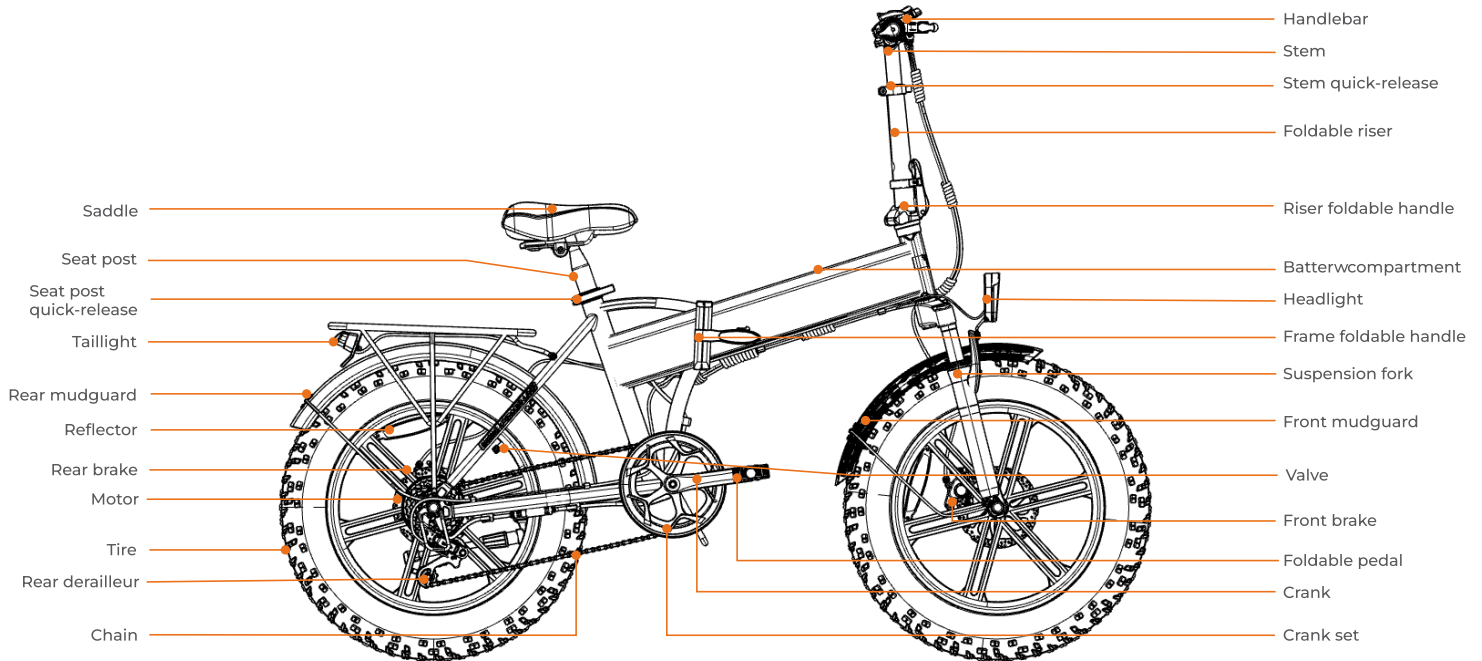

1. Introduction

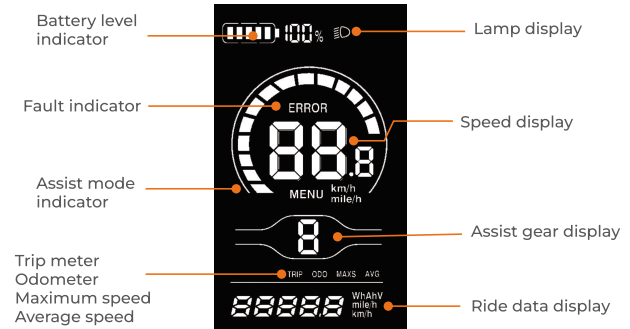
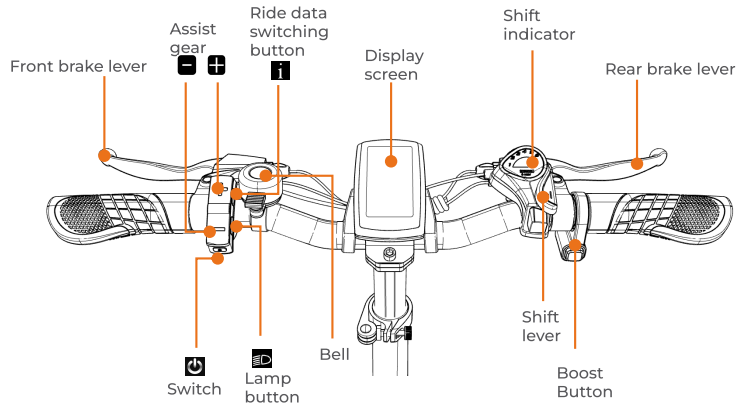

Common functions

1. Power-on/off: press for 1 s to power on, and hold for 3 s to power off.
2. Assist gear adjustment: press / to adjust the gear.
3. Assist: press and hold the button to enter the assist mode. The speed is 6KM/H, and the screen displays the assist mode icon . Release the button , then the assist mode stops immediately, and the assist mode icon disappears.
4. Boost button: In addition to the normal assist mode, it can also supports Boost mode, which can continuously provide additional power for a short period of time, during which it can help you ride with greater torque, suitable for uphill riding and off-road riding. Press and hold the button to activate the Boost mode. If you stop pedalling during the effective time, there will be no power assistance.
5. Headlight switch: press button, the lights turn on, and instrument brightness will dim; Press the button again, then the lights are turned off and instrument brightness is restored.
6. Riding data switching: after the instrument screen is turned on, the instrument screen will display the real-time speed and trip meter by default. Press the button to switch the display information between the trip meter, odometer, maximum speed and average speed.
7. Fault code indication: when the electronic control system of the electric bike fails, the instrument will automatically display the fault code. For the definitions of fault codes, see 3.3 Fault codes.

1.3 Functions

- Warning: The bike shall be disassembled and assembled by two individuals. Before assembling, make sure that the power system is turned off and will not be turned on accidentally.

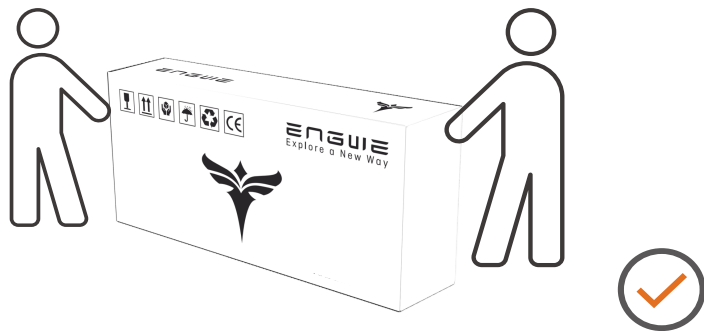

 Maximum load 150KG

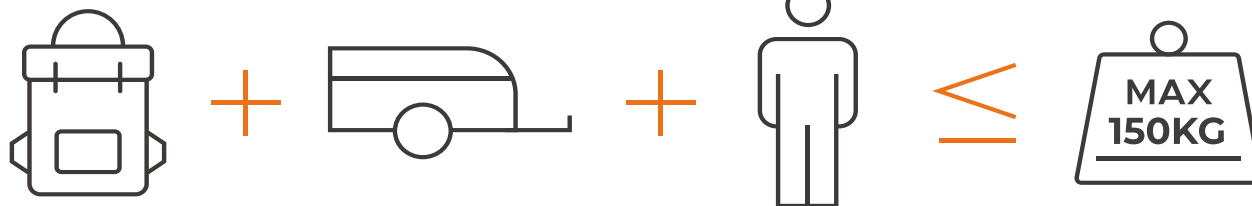

2. Quick guide



1



2

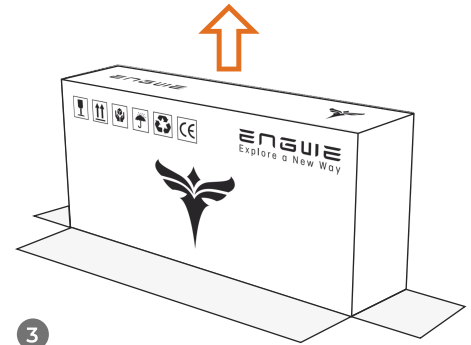

3



Hold the product
to prevent falling

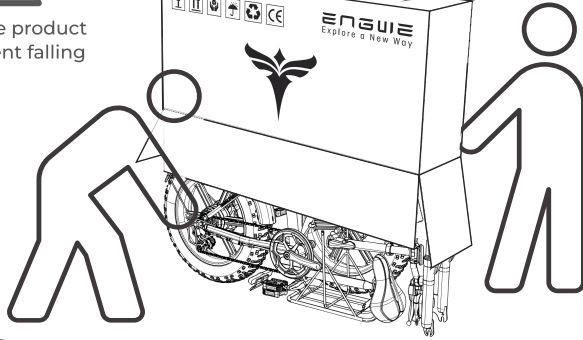

4

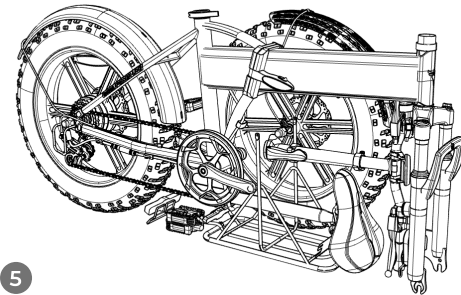

5

Warning: Clockwise direction is to tighten, counterclockwise direction is to loosen.

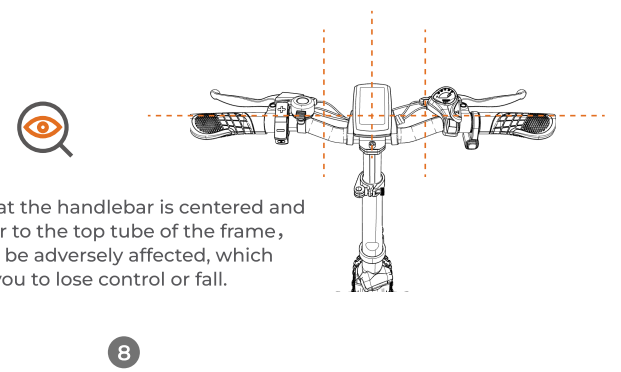
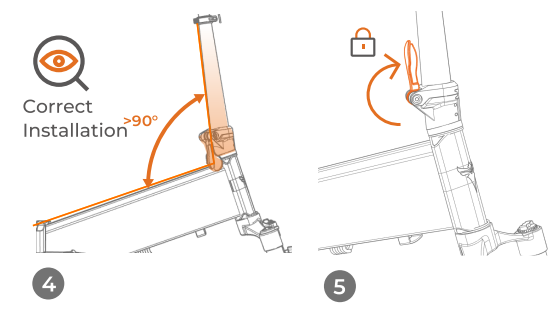
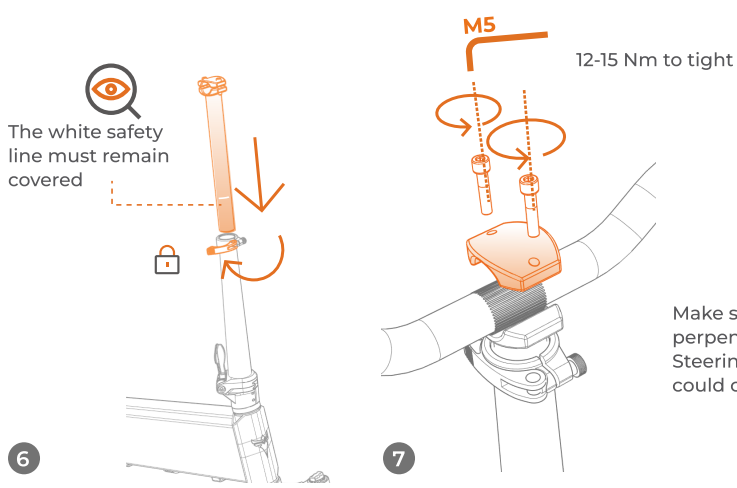
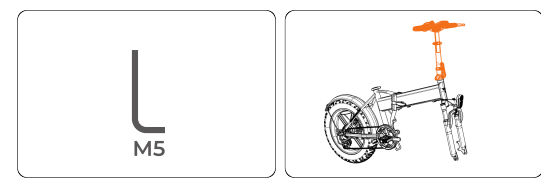
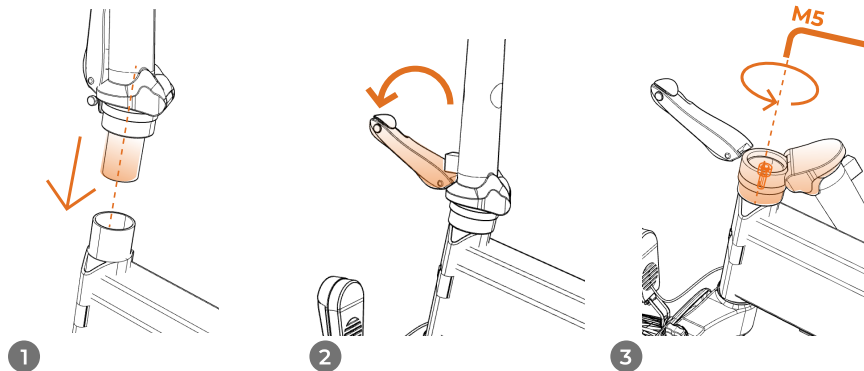

2. Quick guide

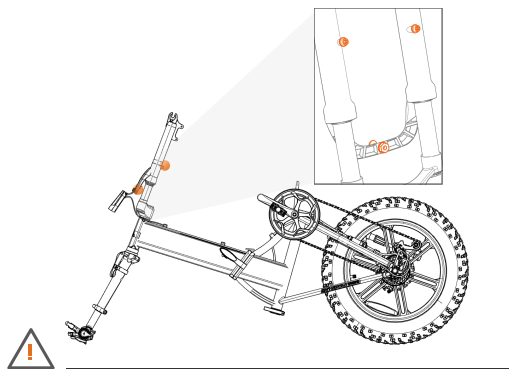

1 Protect the instrument screen. Do not press it

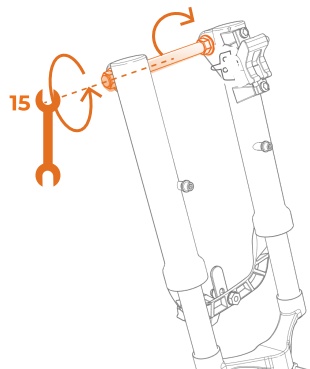

2

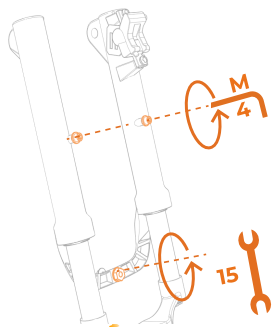
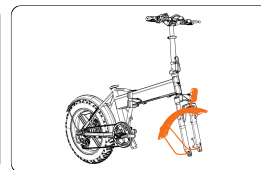
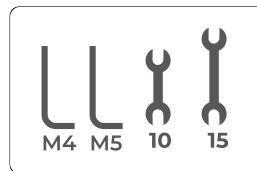

3

Remove the screws and nuts for later use

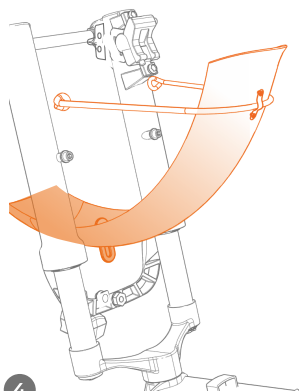

4

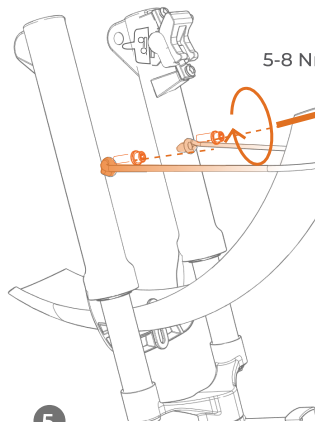

5

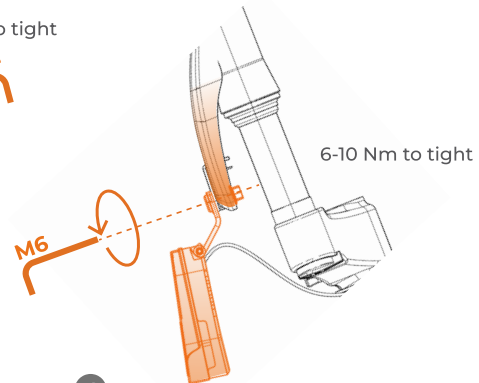

6

2.1.4 Installation guide - front mudguard and headlight

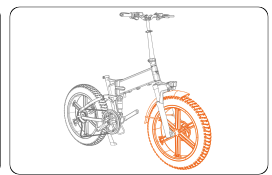
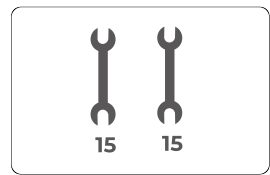
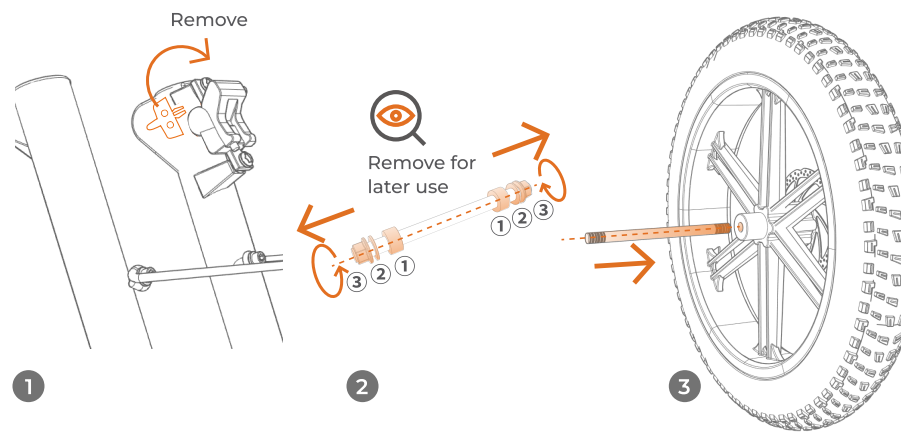

35-40 Nm to tight

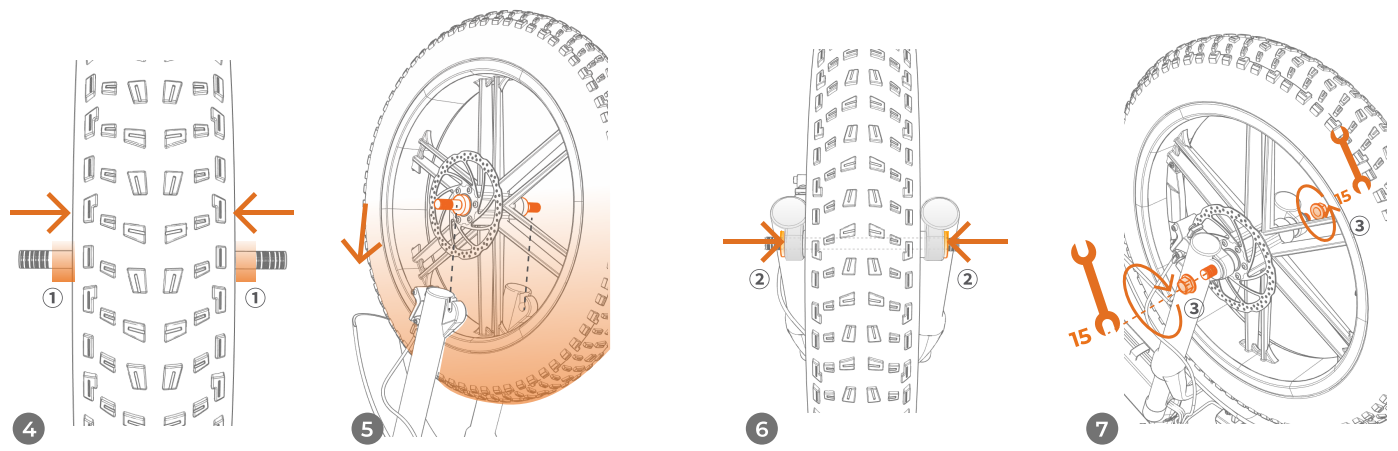

2. Quick guide

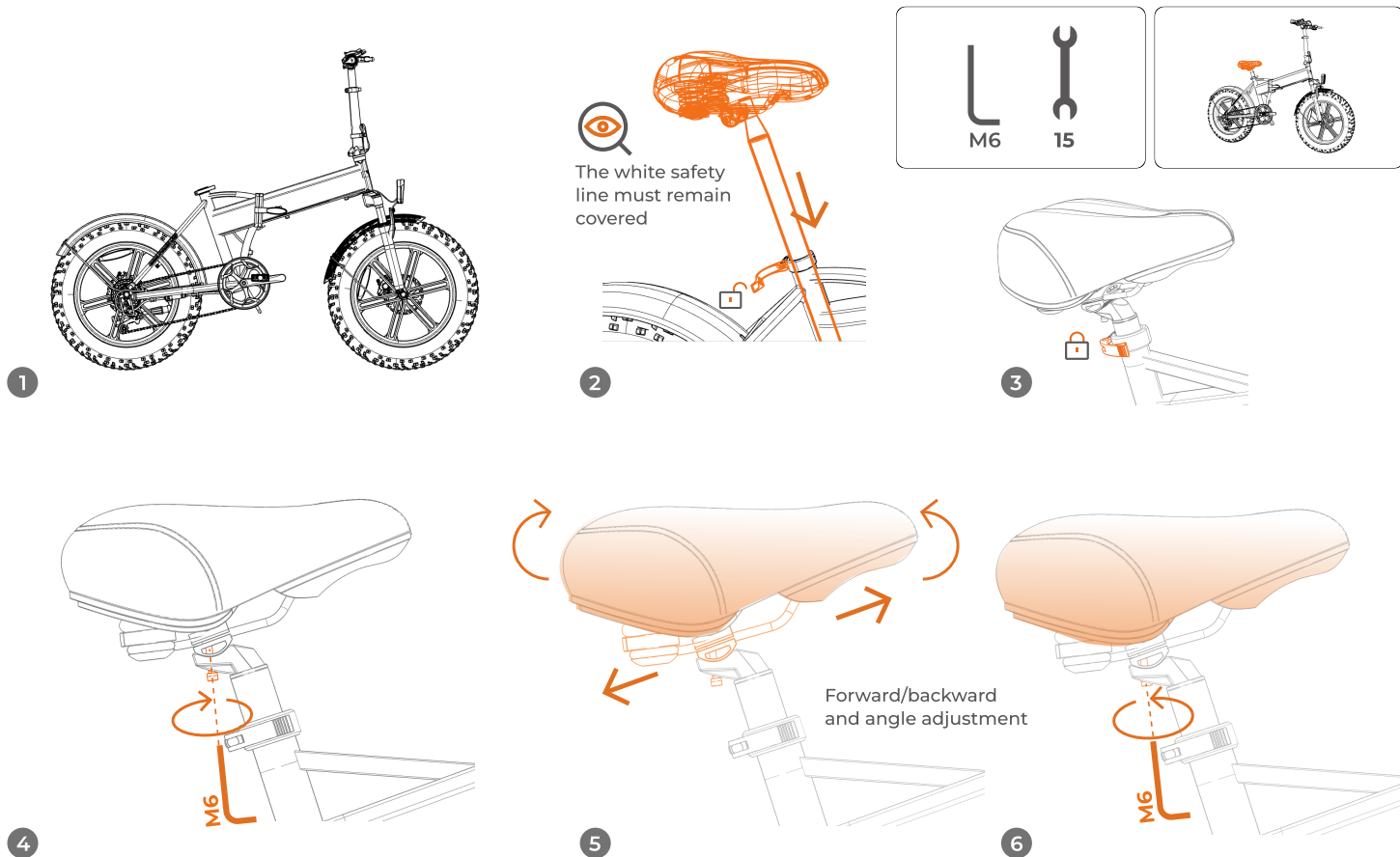

2.1.6 Installation guide - saddle adjustment



Remove the screws
for later use

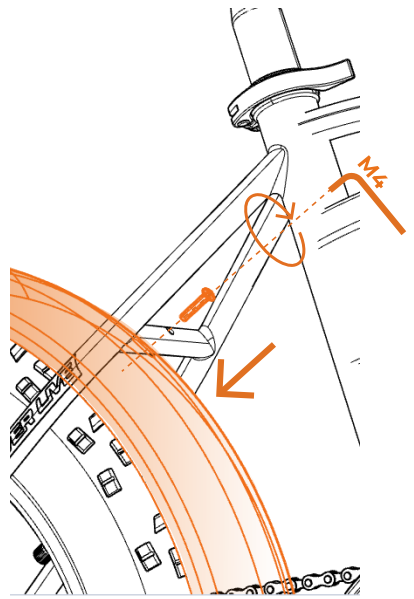

1

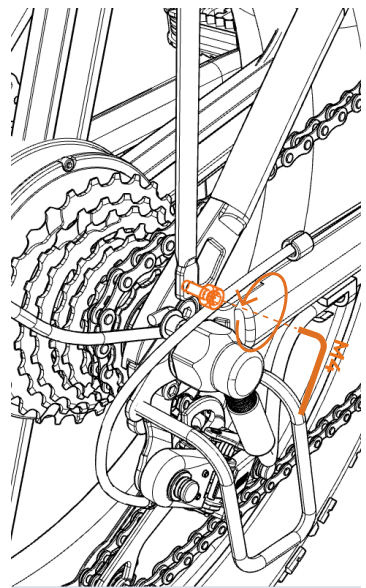

2

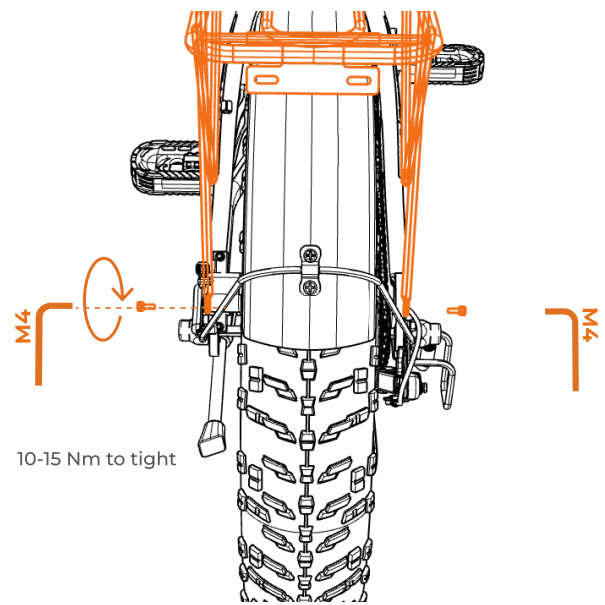
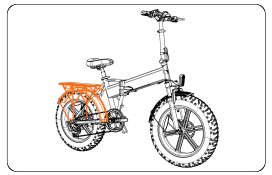

3

2. Quick guide

Warning: Clockwise direction is to tighten, counterclockwise direction is to loosen.

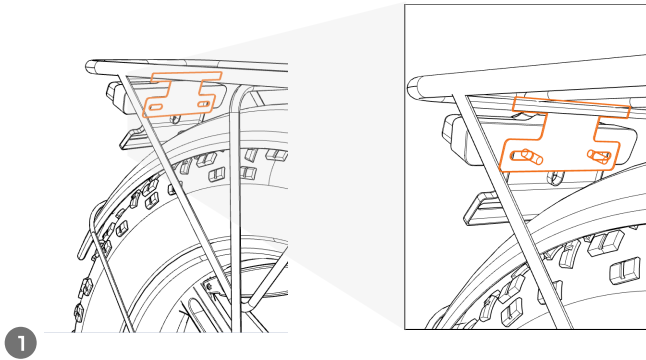

Make sure that the
holes are aligned

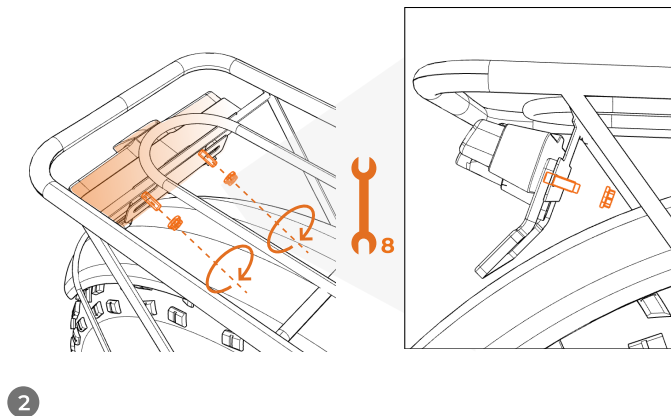
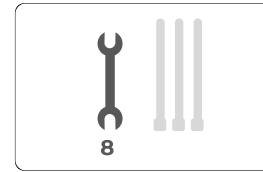

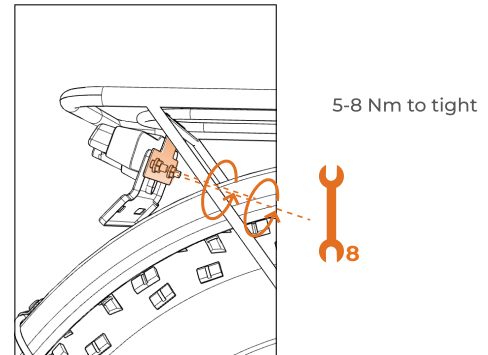

Make sure that the
holes are aligned



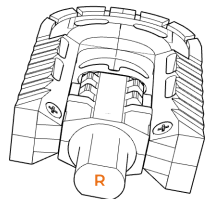
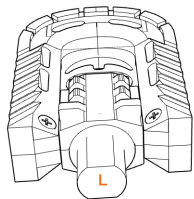

Distinguishing between left and right



1

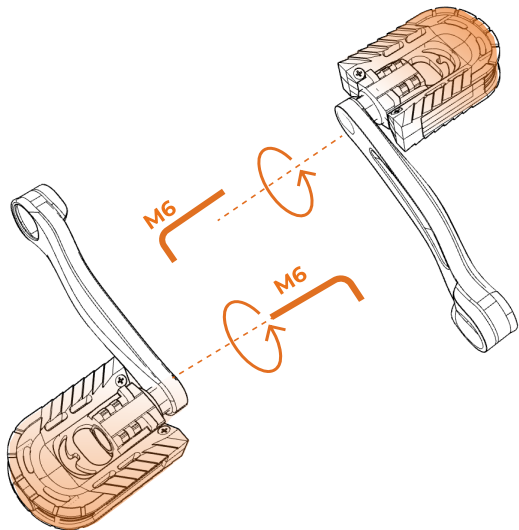

2

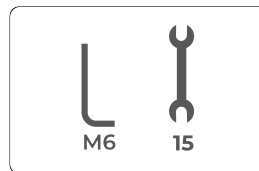

35-40 Nm to tight



3

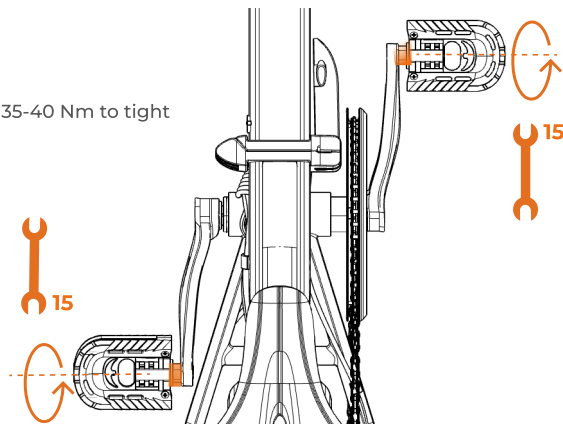

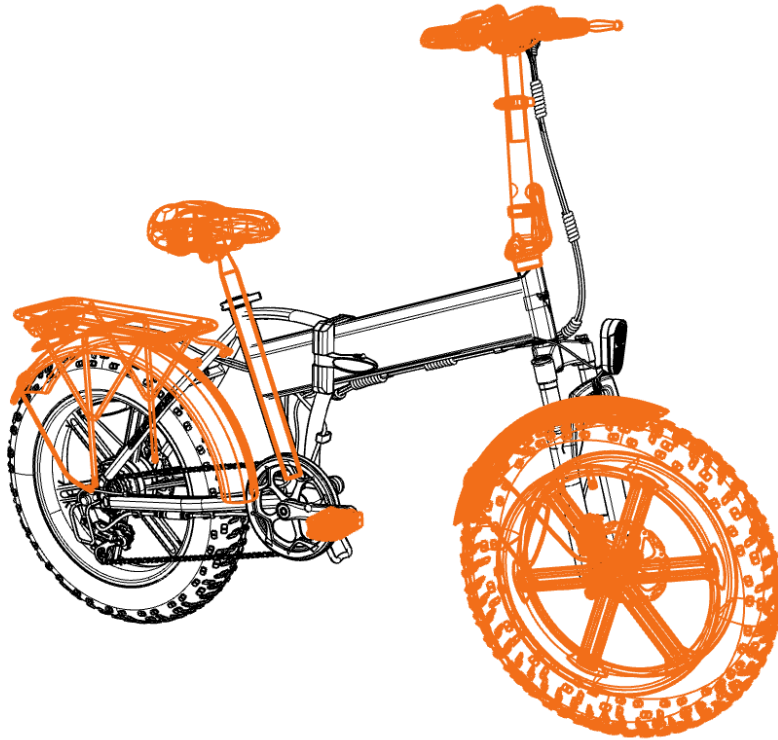

Congratulations!
Your bike has been assembled
successfully!

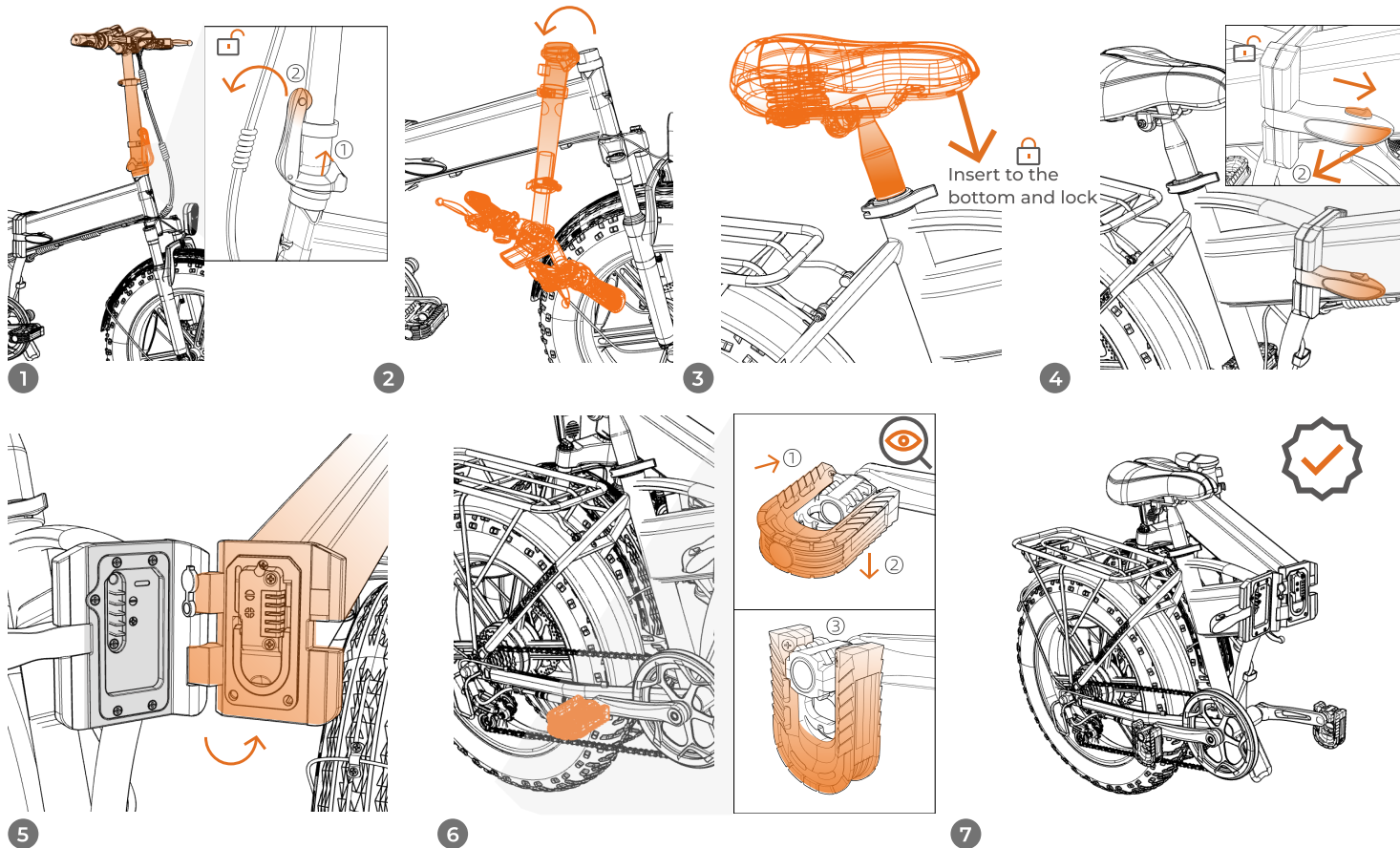

2. Quick guide

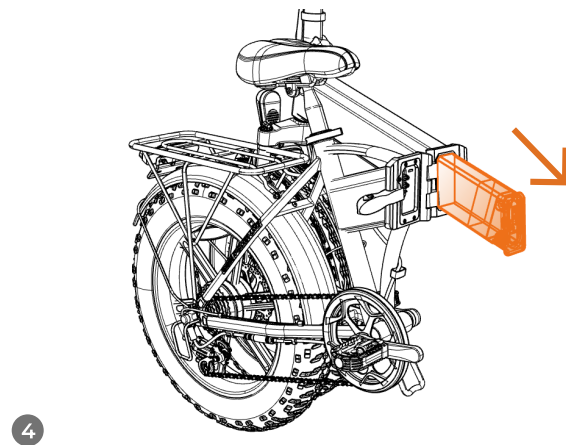
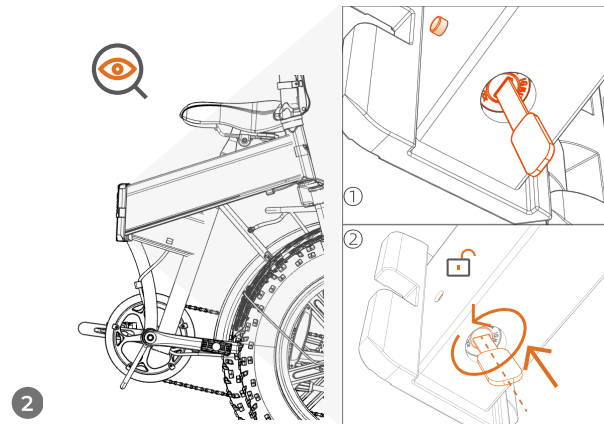
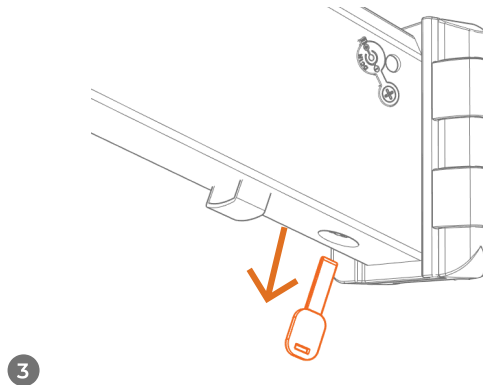
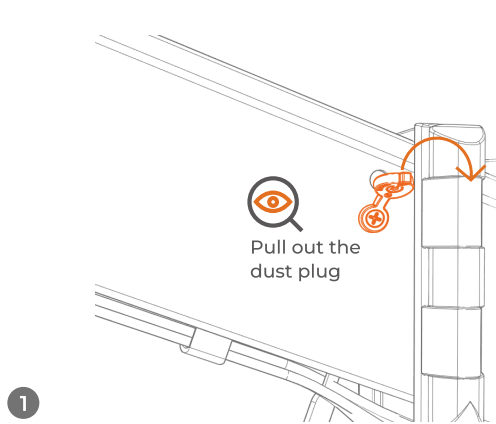

2.3 How to remove the battery

Two Charging Methods

① Charge the battery on the frame directly



⊖ Charging port

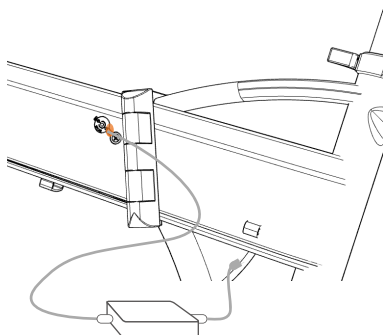

② Remove the battery for charging (see 2.3 for the removal method of the battery)

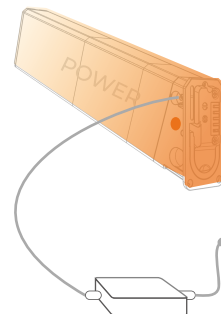

- Note: The battery remains a small amount of electricity when the product leaves the factory. Before the product is used for the first time, please charge it fully. Please make sure to use the manufacturer's original charger that comes with the bicycle to charge the bicycle battery. Non-original chargers may cause battery damage.

Steps

- 1. Start of charging:** Fully insert the charger connector into the battery's charging port, and then fully insert the charger's power plug into the power socket.
- 2. Status indication:** When the charging indicator lamp on the charger is red, it indicates that the charging is normal; When the indicator lamp is green, it indicates that the battery is fully charged.
- 3. Charging time:** about 6-8 h.
- 4. End of charging:** Unplug the power plug first, and then remove the charger connector from the battery. To charge by the method indicated in ①, just close the battery's dust plug. to charge by the method indicated in ②, you must insert the battery into the frame and secure it, and then close the battery's dust plug.

- Note: The charger contains a high-voltage device. Unauthorized repairs are strictly prohibited due to the risk of danger. The battery and the charger must be placed in a safe, well-ventilated, and dry area, beyond the reach of children, and away from any flammable, explosive, or hazardous items (such as saddles, sofas, etc.). Additionally, charging may not be conducted outdoors to prevent accidents like electrical short circuits and fires due to rain or similar elements.
- Warning: If you detect an unusual odor or if the battery or charger becomes excessively hot during charging, stop charging immediately and contact the after-sales team.

2. Quick guide

Before using the product, please follow the installation guide for proper assembly of the corresponding components, verify that all fastening parts are secure, confirm the battery is fully charged, and take appropriate protective measures for riding.

Step 1: Adjust the handlebar and saddle

Please adjust the handlebar and saddle to the appropriate heights for the rider, and make sure that the seat post quick-release hoop and the stem quick-release hoop are securely fastened.

- Note: For optimal comfort, adjust the handlebar to a height that suits your riding style. The saddle should be set at your pelvic height and must not exceed the maximum safe scale.

Step 2: Power on and adjust the headlight

1. Turn on the battery's power supply: insert the key into the battery lock and rotate it fully. The key should be aligned parallel to the frame at this point.
2. Press the power button for about 1 s; the screen will light up.
3. Turn the lights on, Adjust the headlight to illuminate the area 10 m ahead.

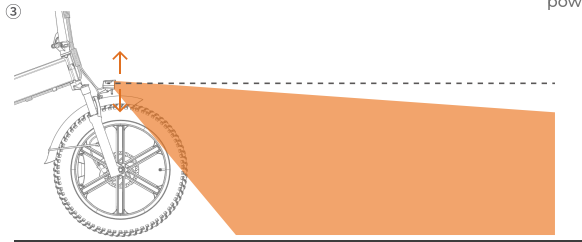
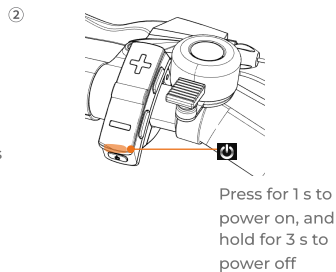
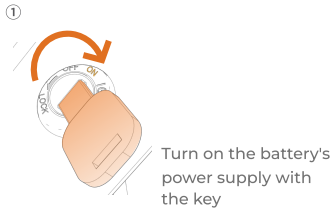

Step 3: Gear shift

Adjust the ride mode according to road conditions and personal needs. The bike is designed with 5 assist gears. Click the power "+" and "-" buttons to shift between gears.

The 1st gear is suitable for riding on relatively flat roads. As the incline of the road increases, you can shift to a higher gear accordingly. Note: When the bike is in PAS mode and the battery is low, you can still ride it like a regular bike.

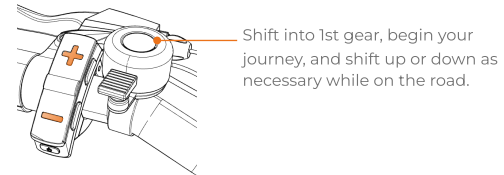

Step 4: Ride on the road

Please put on a helmet before riding on the road.

Step 5: Brake

The left brake is intended for the front wheel, while the right brake is intended for the rear wheel. To brake, first engage the right brake, followed by the left, to slow down the bike until it comes to a complete stop.

- Warning: Avoid abruptly applying the front wheel brake on its own, as this can easily destabilize the bike's center of gravity and lead to a

2.5 Quick operation

If the default settings do not meet your needs, you can personalize the settings as follows:

1. Enter the personalized settings interface: in power-on state, press and hold the buttons **+** / **-** at the same time for more than 2 s;
2. Switch to the personalized settings interface: press the buttons **+** / **-**. There are 18 setting interfaces from 01p to 18p. The following describe each interface respectively

- 01P/bL: Backlight brightness setting. 01/bL-1 represents the darkest, while 03/bL-3 represents the brightest.
- 02P/Un: Metric/imperial unit setting. 00/U-2 means the metric system, while 01/ U-1 represents the imperial system.
- 03P: Rated voltage setting. The default value is 48 volt. It is not recommended that you modify this value. Otherwise, the battery level indication will be inaccurate.
- 04P: Auto shutdown time setting. The auto shutdown time range can be set as follows: 00-60MIN. 00 represents no auto shutdown. The default auto shutdown time is 10MIN.
- 05P: Assist gear setting. European version: 0-3 gears, 1-3 gears, 0-5 gears, and 1-5 gears. For the American version, 0-7 gears, 1-7 gears, 0-9 gears, and 1-9 gears are added. For both versions, the default is 0-5 gears.
- 06P/Ld: Wheel diameter setting, with adjustable wheel diameter range on instrument: 1-32 INCH. The default value is 23 INCH. It is not recommended that you modify this value. Otherwise, the speed indication will be inaccurate.
- 07P/h-: Speed sensor magnet number setting option, with the adjustable range of instrument speed sensor magnet number of 1-255. The default value is 06. It is not recommended that you modify this value. Otherwise, the speed indication will be abnormal.
- 08P/LS: Speed limit setting. The default value is 25km/h (European version) or 28MPH (American version). For the European version, this value cannot be modified. For the American version, this value can be modified, but not more than 28MPH.
- 09P: Zero speed start/non-zero speed start setting. The available start modes on the instrument are as follows: 00 means zero speed start, while 01 means non-zero speed start. The default setting is zero speed start - 00.
- 10P: Drive mode setting. The available drive modes on the instrument are as follows: 00 means only assist drive, 01 means only electric drive, while 02 means both assist drive and electric drive.
3. Enter the parameter change state: press **!**, then the displayed parameter will flash. at this time, press the buttons **+** / **-** to adjust the parameters;
 4. Save the parameter settings and go back to the settings interface: press the button **!**;
 5. Save the parameter settings and exit the setting interface: press and hold the button **!**.

• Note: This model does not support 11p, 12p, 13p, 14p, 15p, 16p, 17p and 18p setting options, which are invalid even if you make such settings.

Restore factory setting (This setting can be used when the current settings are unclear.)

1. Enter the factorwsetting interface: press and hold the buttons **!** and **+** for more than 2 s. dEF means the factorwsetting.
2. Switch between parameters: press the buttons **+** / **-**. dEF-Y means resetting to default parameters, while dEF-N means not resetting to default parameters. select Y.
3. Confirm resetting to default parameters: press **!** for confirmation, then the instrument will display dEF-D for a while and automaticallwstart to restore the factorwsettings. After the resetting is completed, the instrument will automaticallwevit and return to the normal displaywinterface.

3. Notes for maintenance

Safety guidelines for electric bike

1. Do not park the electric bike in the building lobby, evacuation stairs, walkways or safety exits;
2. Do not charge and park the electric bike in the residential building. Keep the bike away from combustibles during charging. The charging time should not be too long, generally not more than 12 h;
3. Prevent water from entering the electrical components. When cleaning the bike, avoid water flow impacting the charging interface, harness connectors and other electrical components;
4. When adjusting the height of the saddle and stem, be careful not to expose the safety scales on the saddle and stem;
5. Users and dealers are prohibited from modifying the bike without authorization. For example: modification of battery configuration, modification of circuit, increase of bulb power, add-on installation of audio devices, etc.;
6. Do not touch the live components of the electric bicycle with wet hands or metal objects. For example: the battery interface, battery charging port, charger connector, etc.;
7. Do not disassemble the electrical components without authorization to prevent liquid and metal filings from entering the components.
8. Do not expose the bike to sunlight/rainstorm for a long time to prevent parts from aging;
9. If the bike needs to be cleaned, please wipe down the frame using water mixed with a neutral detergent. Do not remove and wash the internal parts with water to prevent short circuits.
10. Do not touch hot surfaces after frequent use, such as touching the disc brake after frequent use of the brakes, or touching the motor after a long ride to avoid burns.

• Note: Maintenance by non-professionals is strictly prohibited. In case of failure of the bike, contact the customer service center or go to a designated professional maintenance station for repair.

Ride safely: Always adhere to national and local traffic laws and remain vigilant for your safety while riding.

1. Individuals under the age of 16 are strictly prohibited from operating electric bikes on the road. Do not lend the bike to those who are not proficient in its use to prevent potential hazards.
2. Please ride in the non-motorized lane, with the maximum speed not more than the speed limit in local regulations;
3. The electric bike must carry people or articles in accordance with the laws;
4. Always wear an appropriate safety helmet and secure the chin strap while riding;
5. When riding in rainy and snowy days, the braking distance will be extended, so pay attention to slowing down; Do not ride in bad weather such as rainstorms;
6. Please carefully abide by traffic rules. Do not ride after drinking, or ride with one hand or with both hands off;
7. When riding, try to wear bright color clothes, not tight, without open cuffs and allowing for free movement, and wear low-heeled shoes or sports shoes when possible.

Notes during ride

1. For the safety of yourself and others, please consciously abide by traffic rules;
2. Wear a safety helmet and take other relevant safety precautions before ride;
3. When starting the bike, gradually accelerate to prevent losing control;
4. In rainy and snowy weather, as the braking distance increases, please concentrate on riding slowly and carefully when riding to prevent sideslip and fall;
5. Before stop, please shift down the mechanical gear to facilitate the next ride.

Inspection before ride

1. Turn on the power supply, check whether the indicator lamps on the instrument are normal, and check whether the power of the battery is sufficient;
2. Check whether the front and rear lights are normal and whether the lighting angle of the headlight is normal;
3. Check whether the horn of the electric bike is in good condition;
4. Check whether the handlebar and seat post are adjusted to the proper positions, and confirm that the fastening screws (or quick-release hoop) are fastened;
5. Check the brake levers. the brakes shall be adjusted to be reliable and flexible in resetting. The taillight shall be on during braking;
6. Check whether the tire pressure is normal, whether there is cracking and abnormal wear, and whether there are nails, stones, glass and other sharp objects inserted;
7. Check whether the wheel screws are tightened firmly, and ensure the pedal reflector is not lost, damaged or contaminated.

Notes for push and stop

1. The power switch must be off while pushing to avoid accidents from unexpected activation of the throttle grip.
2. When pushing the bike uphill or carrying heavy objects, the boost mode can be on to assist the push;
3. When stopping the bike, please set the kickstand on the flat ground and power off the bike;
4. Please maintain and clean the bike regularly to keep it in the best condition.

3.1 Notes for operation

Maintenance and self-inspection of bike

1. The electric bike has been adjusted before leaving the factory. If you have any questions, please contact the manufacturer or supplier;
2. Always check the tire pressure to keep it within the normal range;
3. Always check and adjust the main components such as handlebar, foldable riser, saddle, seat post, front and rear axles, bottom bracket, flywheel and chain, front and rear wheels to make sure the transmission parts are flexible and free of abnormalities. The loosened nuts or screws shall be tightened in time;
4. It is recommended that the parts to be lubricated (such as front axle bearing, bottom bracket bearing, rear axle bearing, fork bowl group, pedal bearing, etc.) be filled with 3# calcium-based lubricating oil (grease) every six months during use; Add 30# oil to the chain, derailleur cable, kickstand and other parts about every two months;
5. If it is found that the wearing parts are damaged, such as brake pad, chain and tires, they can be replaced with parts of the same model and specification at a nearby maintenance center .
6. Do not use strong water flow or close-range steam jet to clean your electric bicycle. Please do not wipe the battery and battery interface with a wet towel or wet paper towel.

 Maintenance of motor

1. Do not open the motor base and end cover after sealing;
2. The motor shall be kept clean, and no foreign matter, corrosive liquid or gas shall enter the motor. The motor housing shall not be knocked or baked to avoid damage to the motor.
3. The waterproof grade of the motor is IPX5. Do not flush the motor with a water gun or submerge the motor in water. When the water level reaches the center of the motor hub, it may cause an internal short circuit of the bike and damage the electrical components.

 Maintenance of battery

1. The lithium battery features a large capacity, long service life and light weight. its service life is closely related to your use method. Do not use the bike till the battery is low. Do not store the bike for a long time. Please develop the habit of frequent charging;
2. Please fully charge the bike for the first time. It is recommended that the bike be charged for 6-8 h each time, not more than 12 h.
3. In the case of no use for a long term, it is necessary to charge the lithium battery for more than 2 h every month. It is strictly forbidden to store the bike with the battery in under-voltage state; Once the battery reaches the under-voltage state, it will be subject to great and irreversible damage.

- **Danger:** Do not disassemble the old battery without authorization. The battery shall be recovered at the location designated by the local government or at the company's authorized maintenance site.
- **Warning:** Keep the battery away from open flames or high-temperature heat sources. Never throw the battery into a fire. avoid exposing the battery to direct sunlight in hot and high-temperature conditions.

3. Notes For Maintenance

Troubleshooting

Symptom	Possible cause	Common solution
The bike fails to work	Low battery Poor connection of electrical parts Incorrect start sequence	Charge the battery Clean and re-tighten the connector Start the bike in the correct sequence (see 2.5)
Insufficient range	Insufficient tire pressure Excessive uphill travel, high wind speeds, frequent braking, and overloading The battery is faulty, damaged or aging	Check whether the tire leaks and inflate the tire adequately Utilize the pedal for assistance while riding or modify your route accordingly Contact the engwe after-sales team for assistance
The battery fails to be charged	Poor connection of charger The charger is damaged the battery is stored for a long time and not charged regularly	Reconnect the charger Replace the charger Contact the engwe after-sales team for assistance
The motor fails to work after power-on	The motor cable is loose or damaged The throttle grip is loose or damaged. The motor is damaged	Reconnect or replace the cable Tighten or replace the throttle grip Contact the engwe after-sales team for assistance
Unusual acceleration or excessively low speed	The throttle grip is loose or damaged, or the battery charge is too low	Tighten or replace the throttle grip and fully charge the battery

Fault code

The engwe electric bike comes with a fault detection system. If the electrical system fails, the instrument will display a fault code. Here are the most common fault codes to assist you with troubleshooting. If a fault code is displayed, please stop operation immediately and contact the after-sales team of engwe.

Fault code	Symptom	E004/E022	Throttle grip fault
E001	Control unit fault	E005/E025	Brake fault (brake lever power-off switch or taillight is faulty)
E002/E030	Communication fault (abnormal communication between the control unit, instrument and motor)	E006/E023	Motor fault
E003/E024	Hall element fault (hall elements in the motor are damaged)	E021	Abnormal Current

3.3 Troubleshooting

4. Service guide

Notes for warranty

1. The accessories will be covered in the warranty in strict accordance with the warranty period;
2. The warranty period starts from the date of purchase;
3. The charger, battery and motor disassembled without authorization will not be covered under the warranty;
4. Other parts of the bike are only covered under the three-month warranty in case of quality problems;
5. When other parts of the bike fail, the maintenance must be carried out at a professional maintenance site. It is not allowed to disassemble and assemble the bike without authorization. The control unit, battery and charger must have intact labels;
6. For repair of the bike, the warranty card, invoice, certificate of conformity and other relevant documents must be presented;
7. The battery shall be subject to a separate warranty, that is, in case of battery problems, the battery shall be returned to the manufacturer to determine whether it is under the warranty coverage according to the battery test, and then the warranty liability shall be carried out accordingly.



Warranty card

User	Organization			
	Name		Tel	
Address				
Purchase Date			Color	
Bike Model			Invoice Number	
Frame Number			Motor Number	

Repair record

Date	Repair Content	Remarks

4.2 Warranty card and repair record

Warranty principles

1. The user shall use the product as described in this manual. For any performance failure caused by the product quality, the company will fulfill its warranty obligations according to the provisions of the consumer protection laws;
2. The company is responsible for repairing faults outside the warranty coverage and the main components after the warranty period has expired. However, appropriate charges will apply.
3. For the replacement of the battery beyond the warranty period, the company will provide the battery at the factory cost. However, the corresponding battery must be collected and sent back to the manufacturer to ensure safety and prevent environmental pollution.

Warranty coverage and duration

Item	Accessory name	Warranty period	Notes for warranty
Basic parts	Frame	12 months	In cases of natural deformation, cracked welds, loose welds, fractures, and other quality issues resulting from substandard manufacturing, the manufacturer will provide replacements in accordance with the warranty terms. Unauthorized modifications, damage from collisions, etc., are not covered under the warranty.
	Fork, handlebar, foldable riser, seat post	12 months	
	Tire	1 month	Tires punctured by sharp objects, parts damaged due to collision, etc. are not covered under the warranty.
	Saddle, brake, brake disc, brake lever	3 months	
	Crank set, pedal, kickstand, mudguard, seat post quick-release hoop, foldable stem quick-release hoop, hub, thumb shifter, rear derailleur, flywheel, chain, bottom bracket, shock absorber	6 months	
Electrical Parts	Control unit, charger, main/auxiliary cables, instrument, throttle grip, torque sensor, battery cover, power-off brake lever	12 months	The manufacturer will make replacement as per the warranty terms for short circuits, burnout, performance failure caused by poor manufacturing, etc.; Water ingress, cable disconnection, man-made damage, etc. are not covered under the warranty.
	Headlight, taillight	6 months	
Motor	Motor core, Hall element, bearing, clutch	12 months	The manufacturer will make replacement as per the warranty terms for problems such as phase loss, burned Hall elements, demagnetization, and abnormal sound of the bearing; Faults such as cable disconnection and water ingress are not covered under the warranty.
Batterw	Battery top cover, battery bottom cover, battery case, motor core	12 months	If the battery fails to charge and its capacity is less than 70%, the manufacturer will make replacement as per the warranty terms (the new battery's warranty period will be calculated according to the remaining warranty period, rather than being calculated from the beginning). Faults due to man-made damage are not covered under the warranty.

• Note: The limited warranty does not apply to any subsequent owner or other transferee of the electric bike.

Product Parameters

Product model	EP-2 Boost	
Frame material	Aluminum alloy	
Maximum load	150KG / 330lbs.	
Maximum speed	25km/h, European version	28mph, American version (5 assist gears)
Motor torque	55Nm	
Battery capacity	624wh Li-ion	
Maximum range	120 km*	
Tire size	20 x 4" Front / Rear	
Tire pressure	Not more than 20 PSI	
Charger	54.6V 2A	
Charging time	6-8 h	
Waterproof rating	IPX5	
Bike weight	30.0kg / 66.1 lbs.	
Maximum load capacity of rear rack	15kg / 33lbs.	

*The maximum range is measured in 1st gear with full charge and a load of 75 kg on a flat surface at 25°C and a relative humidity of 70%. The actual results may vary due to the differences in gear, temperature, load, wind speed, road conditions and other factors.

Service hotline:

+33805980036(EU) Working time: 9am to 6pm(GMT+1), Monday to Friday.

+39 800776809 (Eu) Working time: 9am to 6pm(GMT+1), Monday to Friday.

+18442007117 (U.S.) Working time: 9 a.m. to 6 p.m.(PST-8 Time), Monday to Friday

Website: www.engwe.com, www.engwe-bikes-eu.com, www.engwe-bikes-uk.com, www.engwe-bikes.de

If you have any questions or suggestions about the manual, please send them to the email address below.

Email: service@engwe-bikes.com



ENGWE
Technical support
video



ENGWE
Manual

