

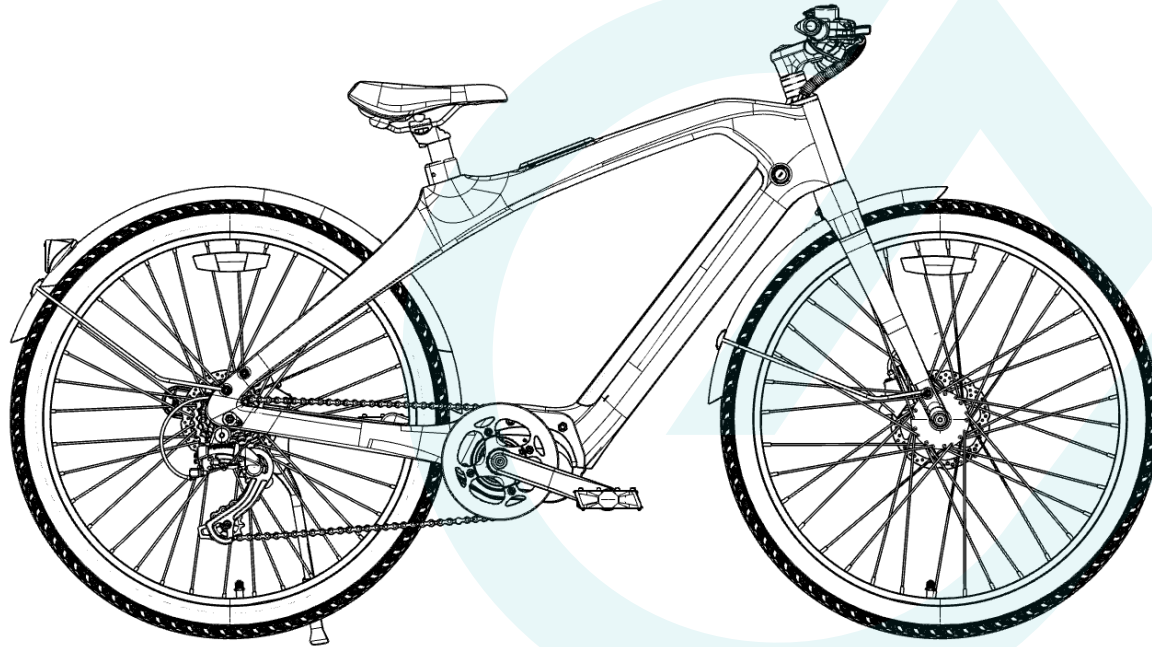

MapFour N1 Pro



CAUTION READ THIS MANUAL BEFORE USING YOUR EQUIPMENT

Dear users

The Owner's Manual describes the essential operation and maintenance methods of the electric bike. To enhance your riding experience, please consult this manual to familiarize yourself with the performance, features, safety notes, and maintenance needs of this product. If you have any questions, please contact the official after-sales team or local authorized service station in time. We will offer you diagnostic assistance as soon as possible.

Safety notes

1. Please ensure you comprehend and adhere to the safety notes outlined in this manual to significantly mitigate risk. Upon entering public spaces, please abide by all national and local laws and regulations. Remain vigilant while riding and maintain a safe distance from others and vehicles.
2. The electric bike must be operated according to the guidelines in the manual. The user will be responsible for any loss resulting from failure to follow the manual's guidelines.
3. This product is not designed for professional off-road biking. Please do not use it as an off-road bike.
4. For your initial ride, choose a private area free of traffic. Once you're comfortable with the product, you can venture onto public roads.
5. Before each ride, please ensure to thoroughly inspect for any loose fasteners or damaged parts. If this product makes abnormal sounds, please stop riding immediately and seek diagnostic support from the official after-sales team.
6. Avoid exceeding the speed limit. Never ride in areas where motor vehicles are present, regardless of the circumstances.
7. For safety reasons, users under the age of 16 are strictly prohibited from using this product. The use of this product is prohibited in the following situations:
 - Individuals under the influence of alcohol or drugs.
 - Individuals unable to participate in strenuous physical activities due to illness.
 - Individuals who are unable to maintain balance or who struggle with balance due to underdeveloped motor skills.
 - Individuals whose weights exceed the limit.
 - Pregnant women.
8. Exercise caution when using this product in bad weather such as snow, rain, slippery roads, and icing.
9. Do not attempt to charge this product if the charger or power supply is wet. When charging this product in a public area, ensure adherence to local safety laws and regulations.
10. For the sake of effective protection and easy use of the bike, always use officially designated parts.
11. If you want to modify your electric bike, please consult the official after-sales team and proceed with caution, ensuring adherence to local laws and regulations. The manufacturer assumes no liability for injuries or bicycle damage resulting from unauthorized modifications.
12. To minimize the risk of injury, please be sure to read and follow all prompts including "Caution", "Danger" and "Warning" in the Owner's Manual.

Danger: Ignoring this warning could result in personal injury. To minimize harm to yourself and others, this notice specifies the actions you must take or avoid!

Warning: Ignoring this warning could result in damage to the bike and its components. This notice specifies the actions you must take or avoid!

Caution: Ignoring this warning could result in minor damage to the bike or impair its normal operation. This notice specifies the actions you should and should not take.

1. Introduction

- 1.1 Packing list
- 1.2 Components
- 1.3 Functions

2. Quick Start Guide

- 2.1 Installation guide
- 2.2 How to remove the battery
- 2.3 How to charge
- 2.4 Quick operation
- 2.5 Display setting & App connecting

3. Maintenance Precautions

- 3.1 Maintenance precautions
- 3.2 Maintenance and self-inspection
- 3.3 Troubleshooting

4. Service Guide

- 4.1 After-sales service and warranty coverage
- 4.2 Warranty card and maintenance records
- 4.3 Product parameters



ENGWE
Technical Support Videos



ENGWE
Manual



ENGWE APP
Download for IOS



ENGWE APP
Download for Android

1. Introduction

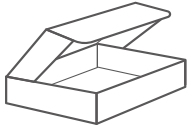

Front Axle
Assembly



Manual



Charger



8-10 13-15 16-18

Wrench



Screwdriver



M3 M4 M5 M6

Allen Key



Kickstand

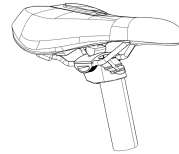

Saddle & Seat Tube



Handlebar

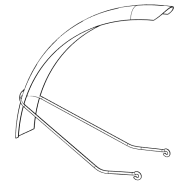

Front Mudguard

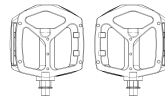

Pedal X2

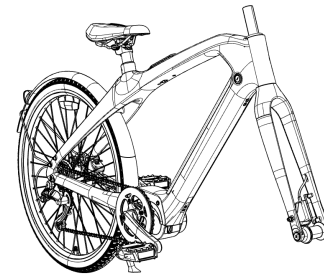

Frame Body



Front Tire



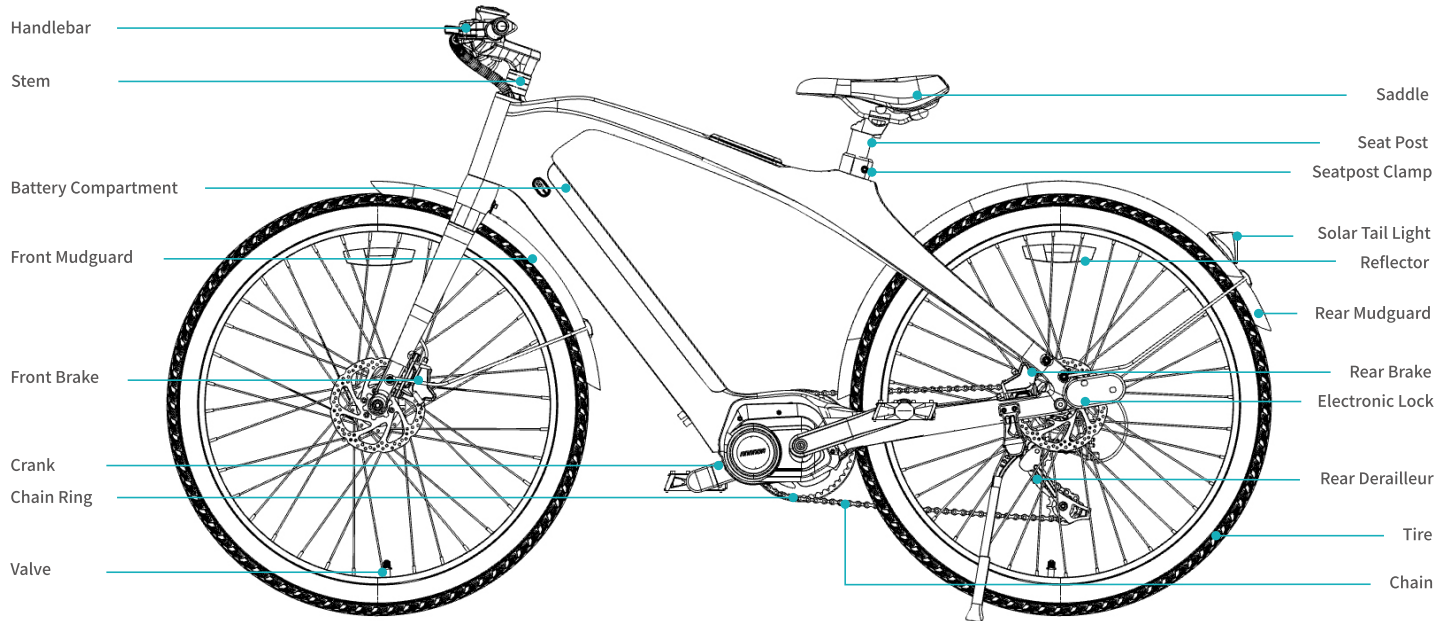



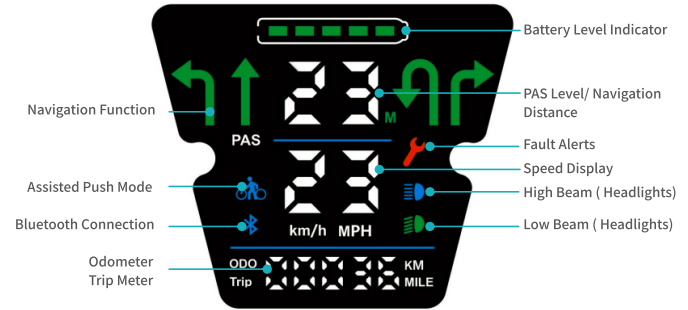
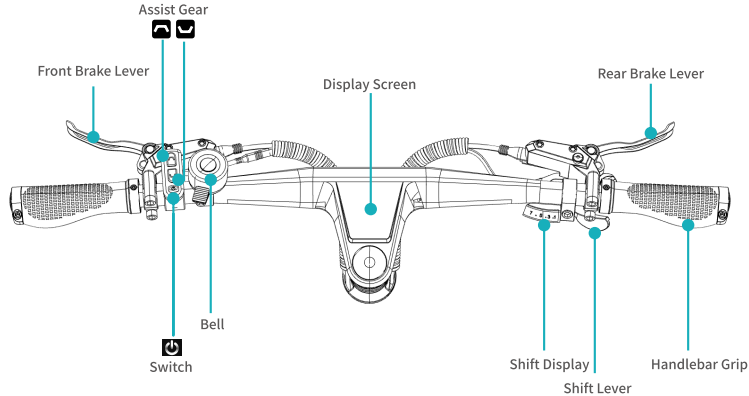











1.1 Packing List



1. Introduction



Common Functions

1. Switch on/off: Press and hold the  button for several seconds to turn on or off.
2. Power gear adjustment: Press the  and  keys to adjust the power gear, range 1-5 gears.
3. Press the  button to enter boost mode at 6km/h, and the boost mode icon  will be displayed. Release the  button to stop power push immediately and the assisted push mode icon  disappears.
4. Lamp switch: Long press  key, lamp on; long press  key again, lamp off.
5. High and low beam switching: Short press  to switch high and low beam, screen high and low beam icon  .
6. Enter setting mode: Long press  key and  key at the same time for 5s, enter setting mode, click  to switch the setting content, click  and  to adjust the value.
7. Error Code Display: The instrument will automatically display an error code  when there is a malfunction in the electric power auto control system. For detailed definitions of the error codes, refer to 3.3 error code descriptions.

1.3 Functions

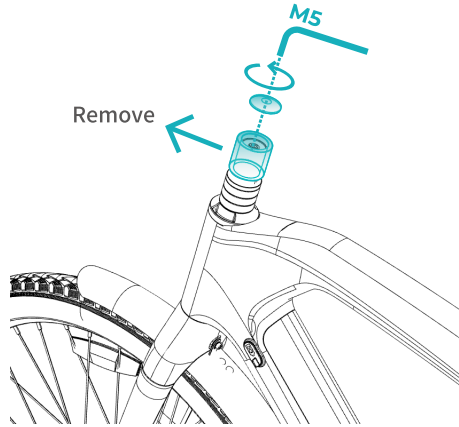

1

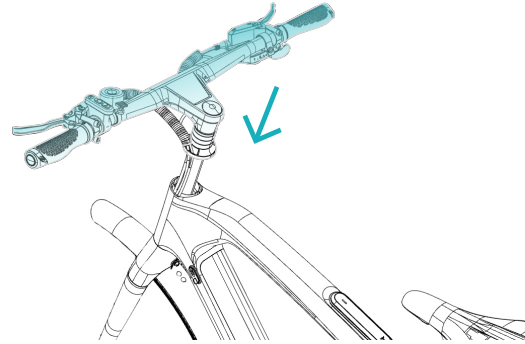

2

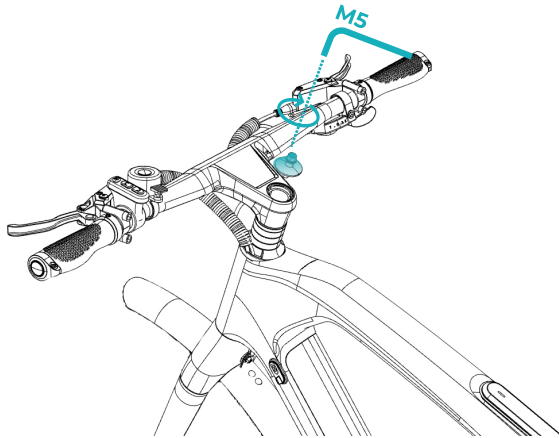
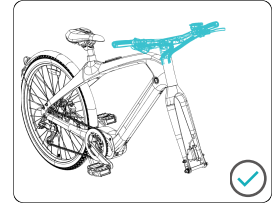

3

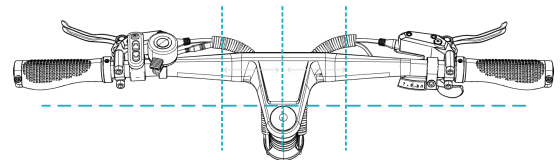

4

Make sure that the handlebar is centered and perpendicular to the top tube of the frame

2. Quick Start Guide

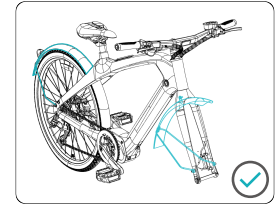
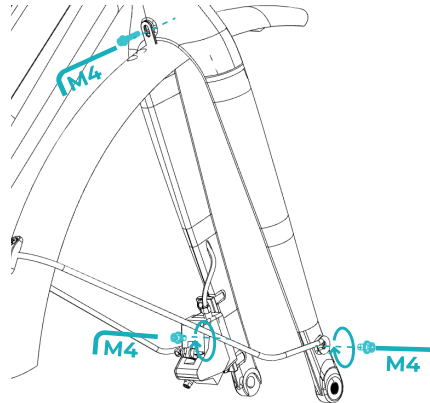
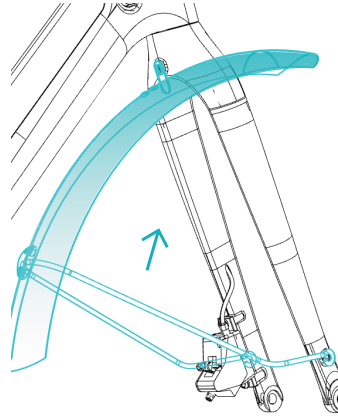
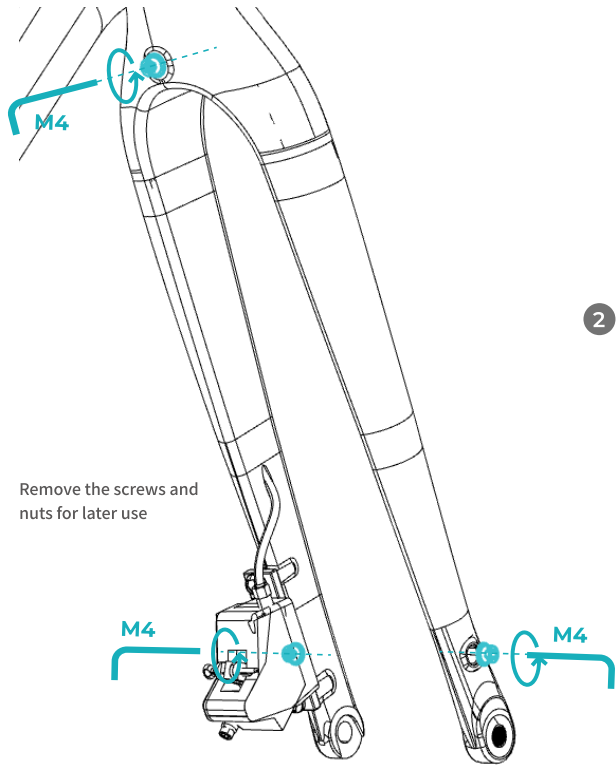

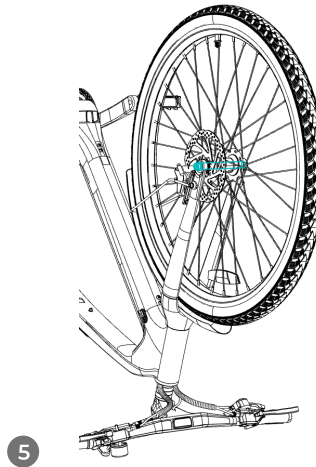
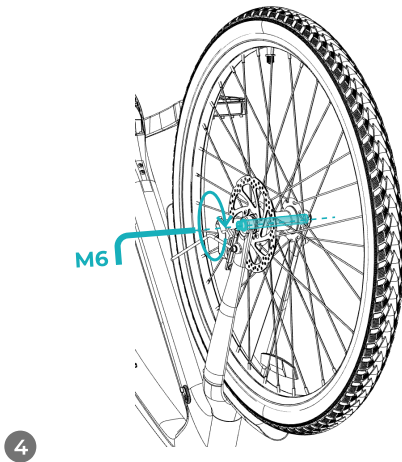
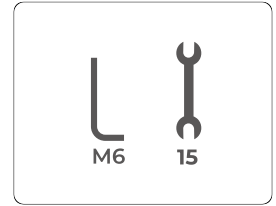
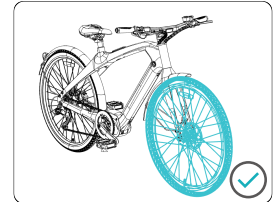
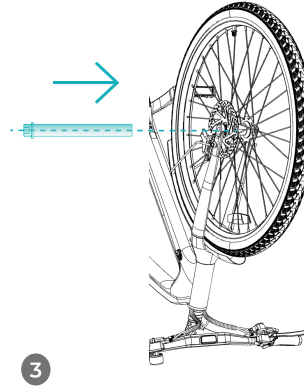
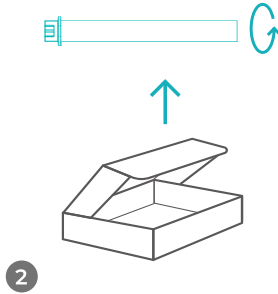
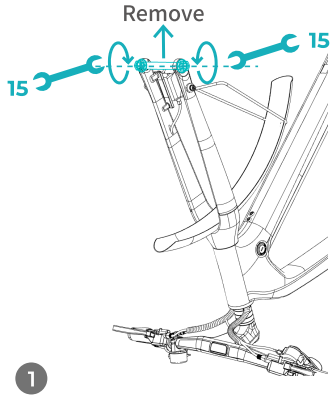

2. Quick Start Guide

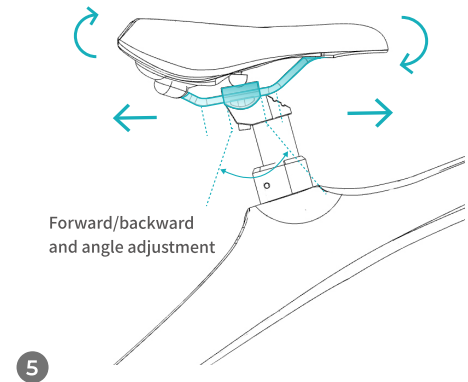
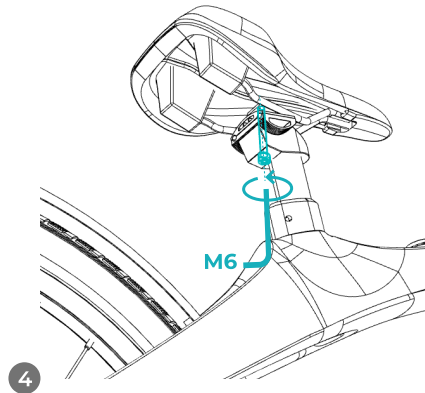
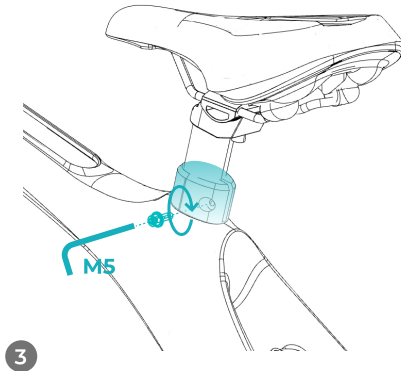
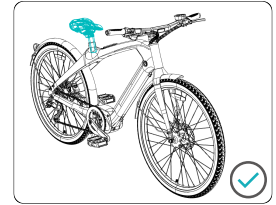
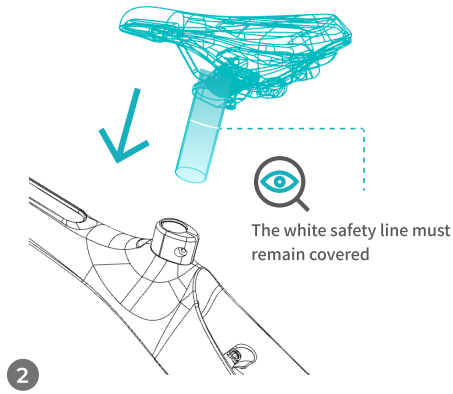
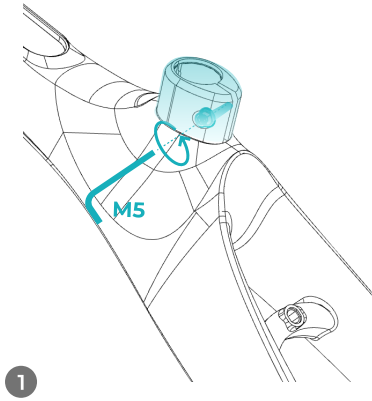

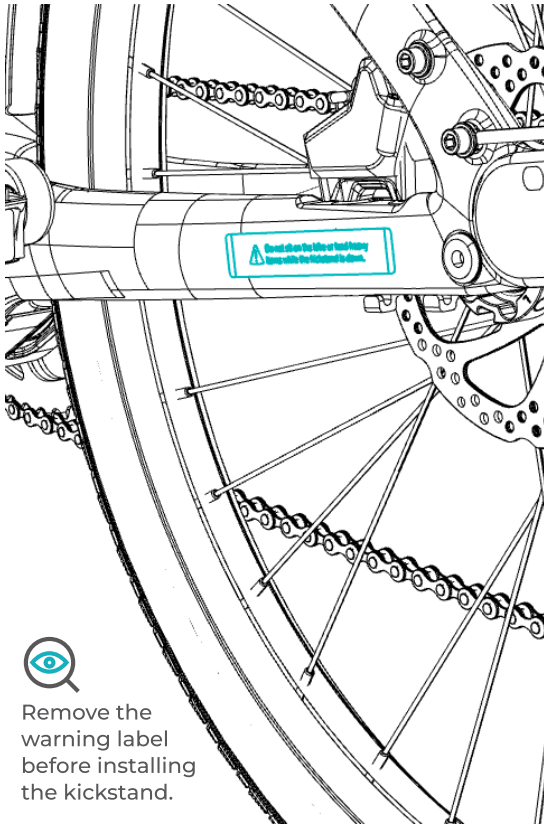

Remove the warning label before installing the kickstand.

1

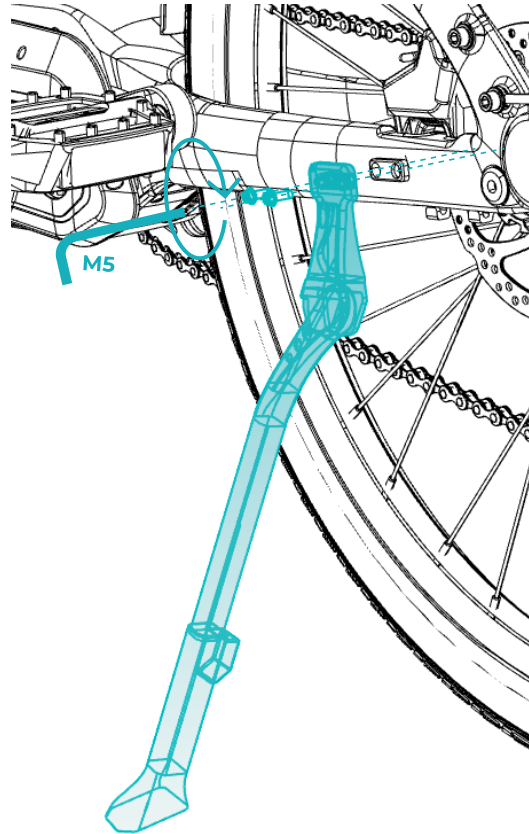

2

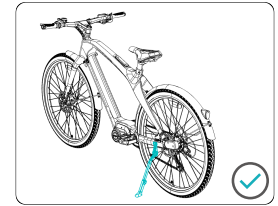

Warning: Do not sit on the bike or load over 25kg while the kickstand is down to avoid damaging the kickstand or the bike.

2. Quick Start Guide

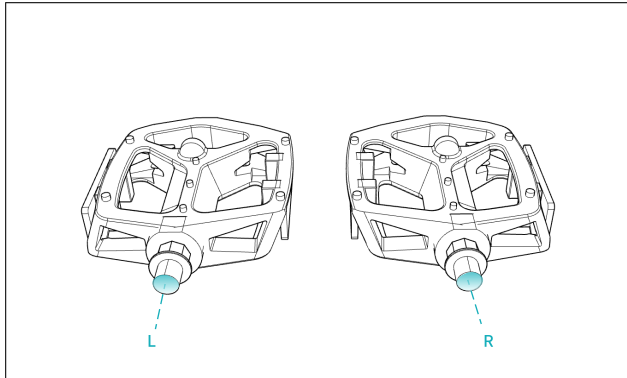

1

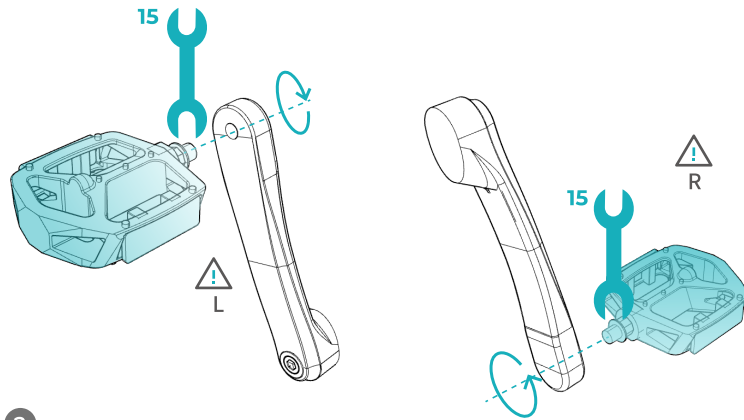

2

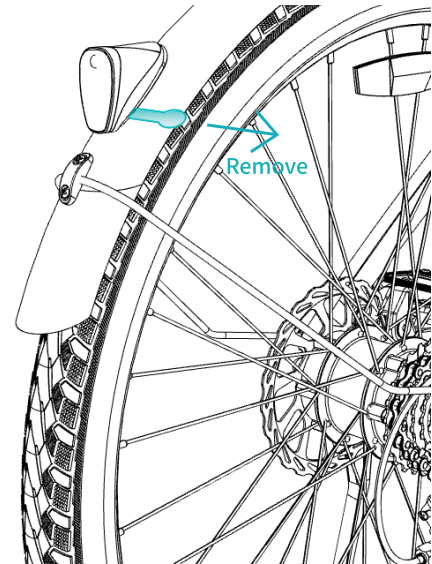
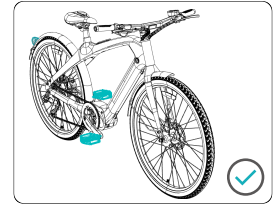
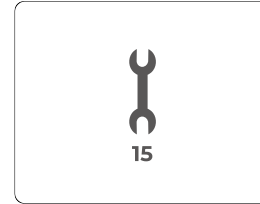

3

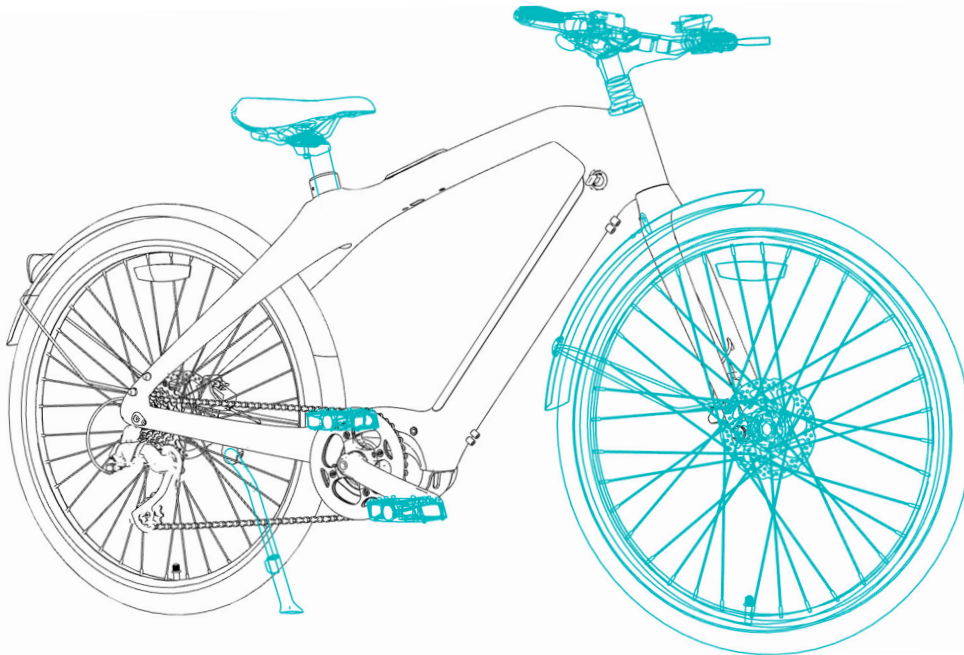

CONGRATULATIONS!
Your bike has been
assembled successfully!

2. Quick Start Guide

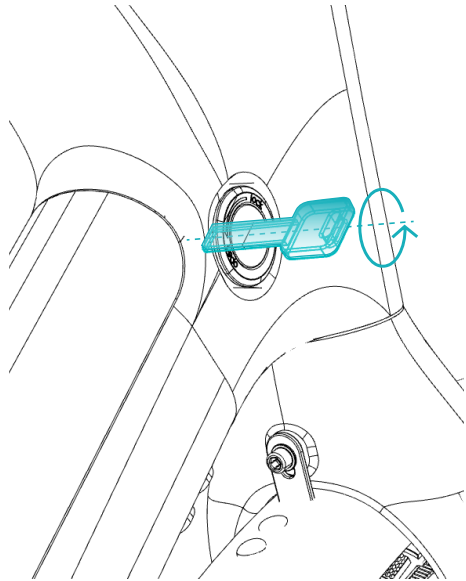

1

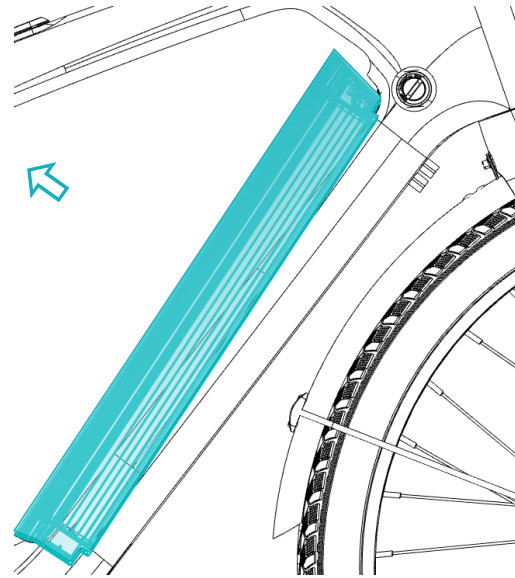

2



To connect your bike to the ENGWE app, please remove the battery, wait for 10 seconds, then reinsert the battery to activate the bike.

Two Charging Modes DO NOT CHARGE IN SUNNY CONDITIONS ! ! !

① Charge the battery on the frame directly

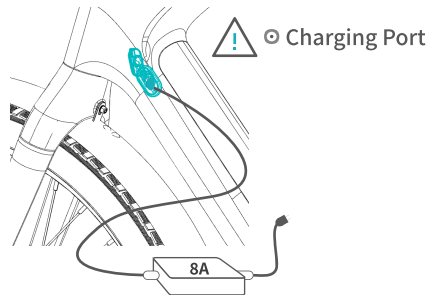

Charging Time: 1.5-2h

② Remove the battery for charging (see 2.2 for the removal method of the battery)

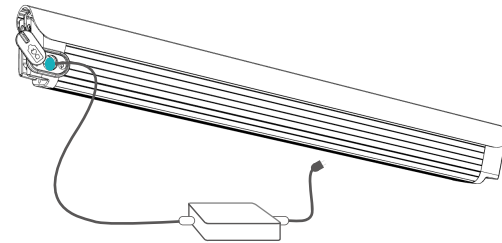

Note: The battery has a small amount of electricity when the product leaves the factory. Before the product is used for the first time, please charge it fully.

Steps

- 1. Start of Charging:** Fully insert the charger connector into the battery's charging port, and then fully insert the charger's power plug into the power socket.
- 2. Status Indication:** When the charging indicator lamp on the charger is red, it indicates that the charging is normal; when the indicator lamp is green, it indicates that the battery is fully charged.
- 3. Charging Time:** about 1.5-2 H.
- 4. End of Charging:** Unplug the power plug first, and then remove the charger connector from the battery. To charge by the method indicated in ①, just close the battery's dust plug. To charge by the method indicated in ②, you must insert the battery into the frame and secure it, and then close the battery's dust plug.

Note: The charger contains a high-voltage device. Unauthorized repairs are strictly prohibited due to the risk of danger. The battery and the charger must be placed in a safe, well-ventilated, and dry area, beyond the reach of children, and away from any flammable, explosive, or hazardous items (such as saddles, sofas, etc.). Additionally, charging may not be conducted outdoors to prevent accidents like electrical short circuits and fires due to rain or similar elements.

Warning: If you detect an unusual odor or if the battery or charger becomes excessively hot during charging, stop charging immediately and contact the after-sales team.

2. Quick Start Guide



Before using the product, please follow the installation guide to install the corresponding components, pay attention to check whether the accessories are loose, ensure that the power is sufficient, and take appropriate riding protection measures.

STEP 1: Adjusting the handlebar and saddle

Please adjust the handlebar and saddle to the proper riding height for the user's height and make sure the saddle tube quick release and the vertical tube quick release are fully fastened.

Note: It is recommended that the handlebar be adjusted to a comfortable height for your riding habits, and the saddle adjusted to the height of your pelvis is optimal, but no higher than the saddle tube safety scale.

Step 2: Switch on the power and adjust the headlight

- ① Turn on the battery power: Long press the  button for about 3 seconds and the screen lights up.
- ② Display Battery Level: Remove the battery, then press the  button, the display of red light indicates that the battery is low.
- ③ Adjusting the high and low beams headlights, short press  to switch high and low beam, screen will display the high and low beam icon.

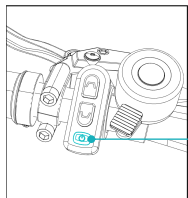

 Long press to power on and power off

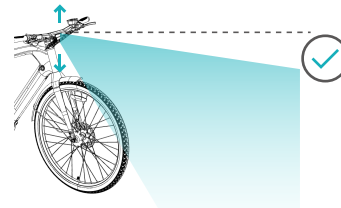
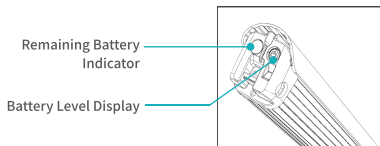

Step 3: Adjusting the riding gear

Switch the riding mode according to the road conditions and personal needs. The bike is equipped with 5 gears, click on the power "+", "-" gear button to switch gears. 1st gear is suitable for relatively flat road conditions, the greater the slope of the road, the greater the gear can be adjusted accordingly. Note: When the bike is in pas 0, there is no power at this time, but it can be ridden as a normal bike.

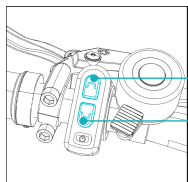

Set the gear to first and start, increase or decrease the gear as required during the ride.







Step 4: Brake

The left brake is intended for the front wheel, while the right brake is intended for the rear wheel. To brake, first engage the right brake, followed by the left, to slow down the bike until it comes to a complete stop.

Warning: Avoid abruptly applying the front wheel brake on its own, as this can easily destabilize the bike's center of gravity and lead to a fall.

2.4 Quick Operation

If the default settings do not meet your needs, you can follow the steps below to customize your settings:

1. Enter the personalization interface: Press and hold down the  and  buttons at the same time for 5s, and enter the system setup password 1212.
2. Switch the personalized setting interface: After entering the setting mode, click to  switch the setting content, click  and  to adjust the value.
3. To save parameter settings and return to the setting screen: Press and hold  and  at the same time for about 5 seconds to exit the setting mode and save the data.

Descriptions of each menu item are provided below, with commonly used functions in bold:

P0: Restore the default parameter settings: Press and hold  button for 20 seconds, all setting parameters will be restored to factory settings.

P1: Screen Brightness: 1~4 , 4 is the brightest;

P2: Metric Switch: 0: Km, 1: Mile;

P3: Sleep time 0~60 minutes: Default 8 minutes.

P4: Single mileage clear. (Value greater than 10 clear)

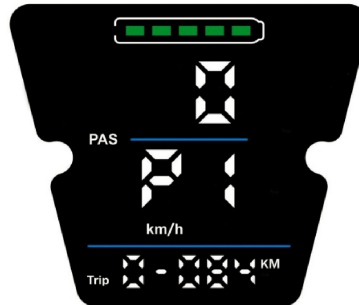

User Guide for Engwe APP

- APP Download and Installation
Search for "Engwe" from App Store/Google Play, or scan the QR code below, then download and install it on your phone.
- APP Login and Registration
- Ebike and IOT Binding
- Tips: If you don't know how to bind your Ebike and use the app, please scan the "ENGWE Technical Support Videos" QR code of the operation manual below.



ENGWE APP
Download for IOS



ENGWE APP
Download for Android



ENGWE
Technical Support Videos

3. Maintenance Precautions

Safety Guidelines For Electric Bike

1. Do not park the electric bike in the building lobby, evacuation stairs, walkways or safety exits.
2. Do not charge and park the electric bike in the residential building. Keep the bike away from combustibles during charging. The charging time should not be too long, generally not more than 12 h.
3. Prevent water from entering the electrical components. When cleaning the bike, avoid water flow impacting the charging interface, harness connectors and other electrical components.
4. When adjusting the height of the saddle and stem, be careful not to expose the safety scales on the saddle and stem.
5. Users and dealers are prohibited from modifying the bike without authorization. For example: modification of battery configuration, modification of circuit, increase of bulb power, add-on installation of audio devices, etc..
6. Do not touch the live components of the electric bicycle with wet hands or metal objects. For example: the battery interface, battery charging port, charger connector, etc..
7. Do not disassemble the electrical components without authorization to prevent liquid and metal filings from entering the components.
8. Do not expose the bike to sunlight/rainstorm for a long time to prevent parts from aging.
9. If the bike needs to be cleaned, please wipe down the frame using water mixed with a neutral detergent. Do not remove and wash the internal parts with water to prevent short circuits.

Note: Non-professionals are strictly prohibited from carrying out maintenance, and should contact customer service or go to our designated professional maintenance station for maintenance in case of failure.

Driving Safety: Please observe national and local traffic regulations and pay attention to driving safety.

1. It is strictly prohibited for persons under 16 years of age to drive electric-assisted bicycles on the road, and do not lend them to people who will not be able to manipulate the electric-assisted bicycle.
2. Please drive in non-motorised lanes and do not exceed the maximum speed limit of local regulations.
3. Electrically-assisted bicycles should carry persons or objects in accordance with the law.
4. Always wear a proper safety helmet and fasten the helmet harness while riding.
5. Riding in rainy or snowy days, the braking distance will be lengthened, so pay attention to decelerating and slowing down. In inclement weather such as rainstorms, try not to use by people travelling in vehicles to avoid danger.
6. Please observe traffic rules carefully and do not drink and drive, drive with one hand or ride with both hands spreading the handlebars.
7. Try to wear brightly coloured clothes that are not too tight, with open cuffs and that allow you to move around freely, and wear low-heeled shoes or trainers wherever possible.

Pre-ride Inspection

1. Turn on the power, check whether the indicators on the instrument are normal, and check whether the power supply is sufficient;
2. Check whether the front and rear lighting is normal, and whether the angle of the headlight lighting is normal.
3. Check that the horn of the electrically-assisted bicycle is in good sounding condition.
4. Check that the handlebar and seatpost are adjusted to the proper position and make sure that the fastening screws (or quick release) are tight.
5. Check the brake handle, brake commissioning should make the brake reliable, reset flexible.
6. Check whether the tire pressure is normal, there are no cracks and abnormal wear and tear, as well as nails, stones, glass and other sharp objects into the tire.
7. Check that the wheel screws are locked and that the stirrup reflectors are not lost, broken or contaminated.

Notes on the Way

1. For your safety and the safety of others, please consciously abide by traffic rules.
2. Before riding, you must wear a safety helmet, as well as take other relevant safety precautions.
3. When the vehicle is first started, accelerate slowly so as not to accelerate too quickly and lose control.
4. In rainy and snowy weather, the braking distance should be increased appropriately, and you should concentrate on riding slowly and cautiously to prevent side-slipping and falling.
5. Before stopping, please lower the mechanical gear for the next ride.

Pushing and Parking Precautions

1. When pushing uphill or carrying heavy objects, you can turn on the boost mode to assist in pushing.
2. When stopping the car, you should support the foot support on the level ground and turn off the power.
3. Please maintain and clean the bike regularly to keep it in the best condition.

3.1 Maintenance Precautions

Vehicle Maintenance And Self-check

1. Electric-assisted bicycles have been adjusted perfectly before leaving the factory, if there is any doubt, please contact the manufacturer or supplier.
2. Check the tyre pressure frequently to keep it in the normal range.
3. Main parts such as handlebar, folding riser, saddle, seat tube, front and rear axles, centre shaft, flywheel and chain, front and rear wheels should be checked and adjusted frequently to make the transmission parts flexible and without any abnormality. loose nuts and screws should be tightened in time.
4. It is recommended that the parts to be lubricated (e.g. front axle bearings, middle axle bearings, rear axle bearings, fork bowl set, pedal bearings, etc.) be filled with 3# calcium-based lubricant (grease) every half a year during use; and that 30# oil be added to the chain, gearshift cable, footrests, etc. every two months or so.
5. If you find that the loss parts are damaged, such as: brake pads, chains, tires, etc., you can find a local repair point to replace them, but be careful to replace them with parts of the same type and specification.



Motor Maintenance

1. Please do not open the motor base and end cover after sealing treatment.
2. The motor should be kept clean, no foreign objects, corrosive liquids and gases should enter the motor, and the motor shell should not be knocked and baked to avoid damage to the motor.
3. The motor is waterproof to ipx5, please do not flush the motor with a water gun or let the motor be submerged in water. When the water level reaches the centre of the hub of the motor, it may cause a short circuit in the internal wiring of the vehicle and damage to the electrical components.



Battery Maintenance

1. Lithium battery has a large capacity, long life, light weight and other characteristics, its service life and your way of use is closely related, do not wait for insufficient power before charging, do not store for a long time, please make a habit of charging frequently.
2. Initial charging can be full, it is recommended to charge for 6~8 hours each time, the longest should not exceed 12 hours.
3. In the case of long-term non-use, you need to charge the lithium battery for more than two hours per month, and it is strictly prohibited to store it at a loss; once the battery voltage reaches the state of loss, it will cause great damage to the battery and can not be restored, resulting in damage to the battery.

Danger: Do not dismantle the old battery without permission, it should be recycled according to the location designated by the local government or by our special maintenance point.

Warning: Batteries should not be close to open flames or high temperature heat sources, batteries should not be thrown into the fire, and are strictly prohibited from being exposed to the sun in hot weather.

3. Maintenance Precautions

General Troubleshooting

Problem	Possible Causes	Common Solutions
Vehicle does not work	Low battery Poor connection of electrical parts starting sequence	Charge the battery Clean and retighten connectors Start the vehicle in the correct order (refer to 2.5)
Poor Mile Range	Insufficient tire pressure High uphill, windy, frequent braking, overloading, etc. Faulty, damaged or ageing batteries	Check tire for air leaks and fill them with sufficient air recommended to ride with pedal assist or to adjust the riding line please contact Engve after-sales team for a solution.
Battery Not Charging	Poor charger connection Damaged charger Batteries stored for long periods of time without regular charging	Reconnect the charger Replace the charger Contact the Engve after-sales team for a solution.
Motor Does Not Work After Power Up	Loose or damaged motor cable Loose or damaged petcock Damaged motor	Reconnect or replace cable Tighten or replace throttle Contact the Engve after-sales team for a solution.
Abnormal Acceleration Or Low Speed	Loose or damaged throttle Low battery	Tighten or replace the throttle Fully charge the battery

Trouble Code

Engve's electrically-assisted bikes are equipped with a fault detection system that allows the screen to display fault codes if there is a malfunction in the electrical system. Below are the most common fault codes to help you troubleshoot the problem. if a fault code appears, stop operation immediately and contact Engve's after-sales team.

Error Code	Error Code Event
0X01	Controller phase line overcurrent fault
0X02	Controller power line overcurrent fault
0X03	Controller hall fault
0X04	Brake fault
0X05	Controller temperature fault
0X06	Motor temperature fault

3.3 Fault Checking and Troubleshooting Methods

Warranty Principles

1. Users should operate and use it correctly according to the requirements of this manual. any performance failure due to production quality reasons, according to the consumer protection law, the company uniformly fulfils the warranty obligation;
2. Failure outside the warranty scope and the main parts after the warranty period, the company is responsible for repairing but need to charge as appropriate;
3. After exceeding the warranty period after the replacement of the battery, the company will always supply at the factory price, but the battery must be recycled one to one and returned to the battery manufacturer to ensure safety and avoid pollution of the environment.

Warranty Coverage And Duration Details

Item	Accessory Name	Warranty Period	Warranty Description
Basic Part	Chassis	12 months	Natural deformation, open welding, desoldering fracture phenomenon, quality problems due to poor manufacturing by the manufacturer to provide warranty replacement; self-modification, collision damage, etc. will not be warranty replacement
	Fork, Handlebar, Folding Riser, Seatpost	12 months	
	Tire	1 months	No warranty replacement for puncture of tire by sharp objects, collision damage of spare parts, etc.
	Seat cushions, brakes, brake discs, brake handles	3 months	
	Crank discs, footrests, foot braces, gears, mudguard, seatpost quick release, folding quick release, hubs, shifting finger pivots, shifting rear pivots, flywheel, chain, centre shaft, shock absorber	6 months	No warranty replacement for human damage, self-modification, collision damage of spare parts, etc.
Electric Component	Controller, charger, primary/auxiliary power cable, gauge, throttle, torque sensing battery cover, power off brake, battery cover, power off brake, battery cover, battery cover, power off brake	12 months	Short-circuit, burnout, performance failure due to poor manufacturing, etc. will be replaced by the manufacturer's warranty; water ingress, broken wires, human damage, etc. will not be replaced under warranty.
	Headlights, tail lights	6 months	
Electrical Machinery	Movement, Hall, Bearing, Clutch	12 months	Problems such as phase failure, burnt-out hall, demagnetisation, bearing noise, etc. are covered by the manufacturer's warranty; faults such as broken wires, water ingress, etc. are not covered by the warranty.
Batteries	Battery top cover, battery bottom cover, battery compartment, cells	12 months	If the battery fails to charge, or the capacity is less than 70%, the manufacturer will provide warranty replacement (the battery warranty period will not be recalculated, and the replacement battery will be calculated according to the remaining warranty period). No warranty replacement for man-made damages.

Note: None of the limited warranty applies to any subsequent owner or other transferee of the electrically assisted bicycle.

4. Service Guide

Warranty Description

1. Parts will be warranted in strict accordance with the warranty period;
2. Warranty time starts from the date of purchase;
3. Private disassembly of the charger, battery, motor, will void the warranty;
4. For other parts of the whole vehicle, there will be no warranty except for three months due to quality problems;
5. When other accessories of the whole vehicle fail, the maintenance must be carried out in a professional repair center, and must not be disassembled privately. controllers, batteries, chargers must ensure that all labelling is complete;
6. When the whole vehicle is repaired, warranty cards, invoices, certificates of conformity and other relevant documents must be presented;
7. Battery warranty to take a one-for-one warranty, in case of battery problems, you need to return the battery to the manufacturer first according to the battery testing standards to determine whether it belongs to the warranty coverage, and then warranty.

Warranty Card

Warranty Card And Maintenance Record

User	Unit (of Measure)		
	Name and surname		Telephone Number
Mail Address			
Date Of Purchase			Colour
Bike model			Invoice Number
Bike registration Number			Motor Number

Maintenance Records

Date	Maintenance Content	Note

4.2 Warranty Cards and Maintenance Records



Product Parameter

Product Model	MAPFOUR N1 Pro
Frame& Fork Material	Carbon Fiber
Maximum Load	120kg / 264lbs.
Top Speed	25km/h
Motor Torque	80Nm
Battery Capacity	360 Wh Li-ion
Maximum Range	100km / 62mile*
Tire Size	700x42C
Tire Pressure	Not more than 20 psi
Charger	36V 8A
Charging Time	1.5~2hours
Waterproof Rating	IPX5
Vehicle Weight	19kg / 41.8lbs.

- Maximum range is measured on a flat road with a full charge, a load of 75kg, a temperature of 25°C and a humidity of 70%, in first-gear power mode. actual results may vary depending on gear, temperature, load, wind speed, road conditions and other factors.

Service hotline:

+33 805980036 (EU) Working time: 9am to 6pm (GMT+1), Monday to Friday.

+39 800776809 (EU) Working time: 9am to 6pm (GMT+1), Monday to Friday.

+18442007117 (U.S.) Working time: 9 a.m. to 6 p.m. (PST-8 Time), Monday to Friday

Official website: www.engwe-bikes.com, www.engwe-bikes-eu.com, www.engwe-bikes-uk.com, www.engwe-bikes.de

If you have any questions or suggestions about the manual, please contact us at the following e-mail address

Contact us: service@engwe-bikes.com



ENGWE
Technical Support Videos



ENGWE
Manual



ENGWE APP
Download for IOS



ENGWE APP
Download for Android