

**iNMOTION**

**V11Y**

***Explore***

**Electric Unicycle User Manual**



Before using your unicycle, please read the instructions, and keep this manual for ready reference.  
Original instructions

***i* NMOTION**

# GETTING STARTED

Thank you for choosing the INMOTION electric unicycle(hereinafter referred to as the unicycle)! This unicycle is an intelligent high-tech entertainment product. When you use the unicycle, there may be situations such as falling or collision that can cause injury and other risks. To reduce possible risks and ensure the personal and property safety of yourself and others, you have the responsibility and obligation to carefully read the user manual, fully understand all the warnings and precautions listed in this manual, and ensure that you can use it correctly. To obtain the latest feature/function information and safety guidance, please download the electronic version from the official website. Important! Read carefully and keep for future reference.

Serial number (referred to as SN below) is a unique identifier for each product, which can be used for product warranty, maintenance, insurance claims, loss confirmation, and so on. The SN is a 16-character numeric code that can be found on the packaging box label, the body of the product, or in the device information section of the associated App. Get closer to your seller so he can refer you to an Appropriate training organization.

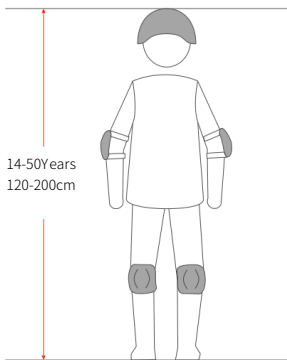

When riding an electric scooter, please wear a helmet, knee pads, elbow pads, wrist guards and other protective gear throughout the journey to reduce the risk of injury.

All pictures in this manual are for reference only. Please refer to the actual product for accuracy.

# BRIEF INTRODUCTION

## Check the Packing List

Please carefully check all components inside the packaging. If any components are missing, please consult your point of purchase.

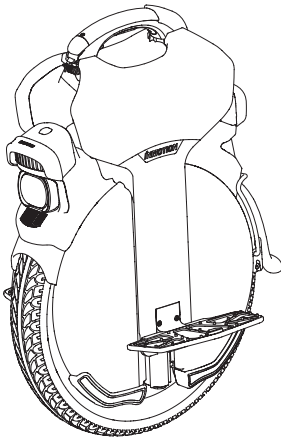

User Manual



Quick Start Guide

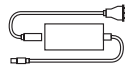

Power Cord /Adapter



Inflator



Wrench \*2



L-shaped wrench\*2



Extended air nozzle



**WARNING:** Please keep the packaging box and packaging materials for at least 30 days for future use when transporting the electric unicycle.

# DIAGRAM

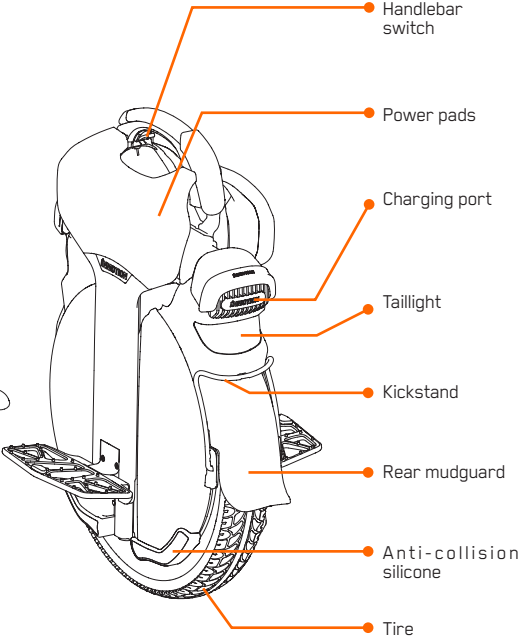
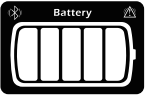
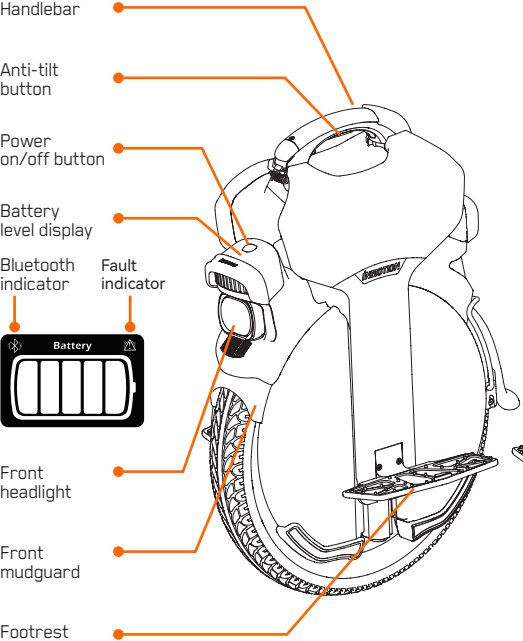

# PRODUCT FEATURES INTRODUCTION

**Power On/Off:** Long press the power button to turn on the device, and in the powered-on state, long press the power button to turn it off.

**Front Headlight:** In the powered-on state, short press the power button to turn on the front headlight. Daytime running light (DRL): By default, the DRL is enabled when the device is powered on and can be disabled in the app or by simultaneously holding the anti-tilt button and the power button. When the main headlight is turned on, the DRL will also be activated simultaneously.

**Taillight:** The taillight will flash brightly when the brake is applied. When the front headlight is on, the taillight will remain constantly lit.

**Anti-Tilt Button:** When the vehicle is stopped, gripping the handle and pressing the button below it will cause the vehicle to lose balance, accompanied by an audible prompt.

**Power Assist:** Enabling this mode helps you achieve a more comfortable acceleration and braking experience.

(1) Acceleration Assist: Adjust the value to obtain a smoother and quicker acceleration experience. A higher value results in faster acceleration.

(2) Brake Assist: Adjust the value to obtain a smoother and quicker braking experience. A higher value leads to a shorter braking distance.

**Charging:** Use the original charger (output voltage: 84VDC/2.5A). The charger indicator will be red during charging and green when fully charged. It supports dual charger usage for faster charging times.

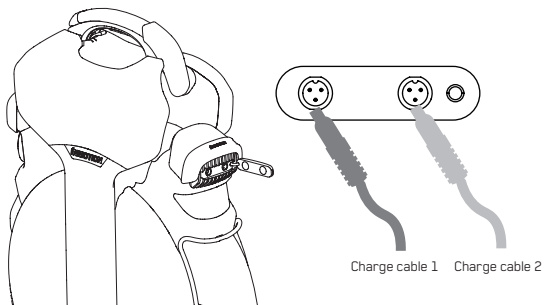

**Handlebar:** Press the button under the handlebar to unlock and extend it. When not in use, hold the button under the handlebar to fold it back.

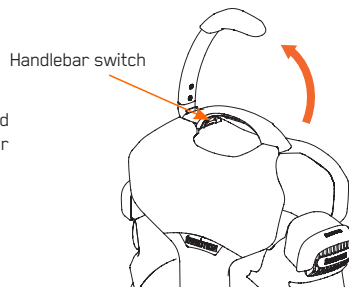

**Shock Absorption:** Equipped with dual air spring shock absorption function.

 **Note:** Before use, be sure to inflate the air springs following the inflation instructions.

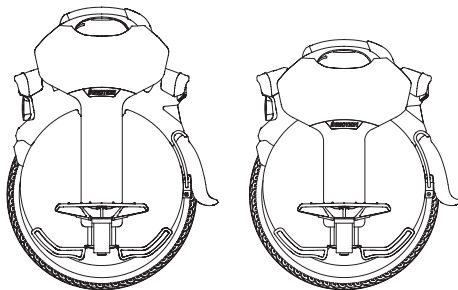

**Parking Stand:** Rotate the parking stand downward to deploy it.

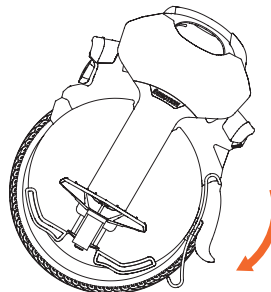

# PRODUCT FEATURES INTRODUCTION

Specification	Item	Argument
Basic Specs	Range (km)	120 <sup>[1]</sup>
	Charging time (h)	6.6h with single charger; 3.3h with dual chargers
	Rated Power (KW)	2.5
	Max.Power (KW)	7
	Max.torque (N.M)	150
	Max.speed (KM/H)	60 <sup>[2]</sup>
	Max.slope (°)	40° <sup>[3]</sup>
Frame	Suspension travel (mm)	85
	Length*Width*Height (mm)	555*180*744
	Net weight (kg)	30.4
	Max. payload (kg)	120
Battery Pack	IP ratings	IPX6
	Rated capacity (Wh)	1423
	IP ratings for battery	IPX7
	Rated voltage (V)	72.6
Motor	Smart BMS	Overcharging protection, over-temperature protection, over-discharge protection, overcurrent protection, short circuit protection, overvoltage protection, and etc.
	Motor size	12inch
	Tire size (Outer cover)	18*3.00
	Tire pressure (BAR)	2.5BAR
	IP ratings for motor	IPX6

[1]: fully charged, 75 kg payload, 25°C, no wind, and cursing at the flat road in 25km/h.

[2]: fully charged, 75 kg payload, 25°C, no wind, at the flat road.

[3]: fully charged, 75 kg rider get the data through a large amount of tests.



<b>Specification</b>	<b>Item</b>	<b>Argument</b>
Charger	Chrger Input	AC 110-220V
	Charger output	DC 84V $\equiv$ 2.5A
Configurationn	Charger interface	GX12-3PIN
	Quantity of charger interface	2
Requirments	Working temperature (°C)	-10-45
	Storage temperature (°C)	-20-45

# DIMENSION

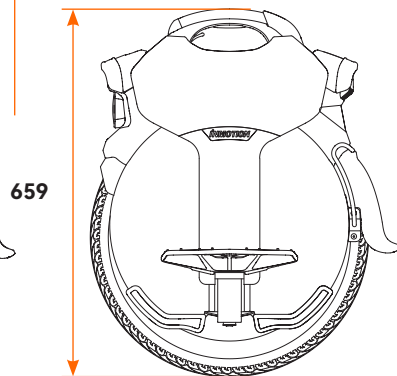
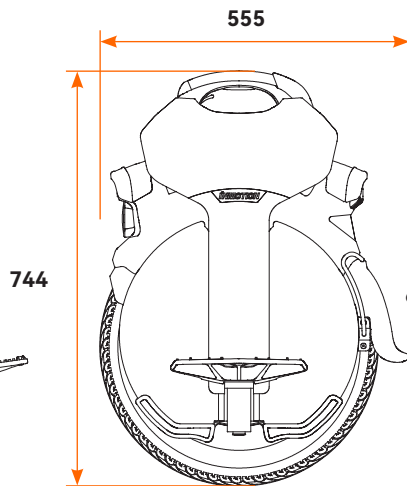
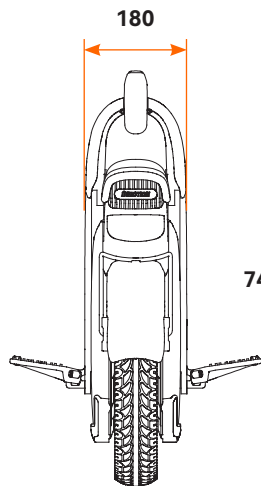
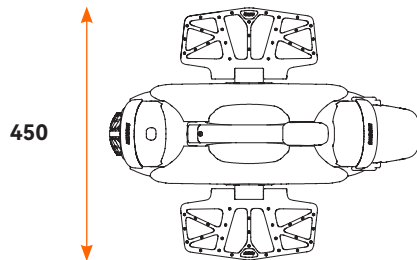

# INITIAL USE

## Preparation Before Use

The unicycle is a high-tech entertainment product. Riding it without understanding the operational guidelines may lead to unforeseen injuries and property damage. The following instructions will provide users with detailed guidance on the correct usage of the unicycle and various precautions while using it. Please read them carefully and use the unicycle as instructed. Before using the unicycle, make sure that all its components are undamaged and properly installed.

### **Warning:**

- **Before using the unicycle, please ensure that the battery is sufficiently charged, preferably to at least 80%.**
- **Find a relatively open and flat area, with a minimum size of 4m\*4m, for your practice, either indoors or outdoors. Familiarize yourself with the driving environment to ensure no interference from cars, pedestrians, pets, bicycles, or other obstacles.**
- **Have a skilled assistant by your side. The assistant should be experienced in operating the unicycle and familiar with all the precautions and instructions mentioned in this manual.**
- **Do not test the vehicle on slippery or wet surfaces.**
- **It is recommended to wear comfortable casual or sportswear and flat-bottomed shoes. Warm-up exercises are advisable to maintain flexibility.**
- **Always wear a helmet and protective gear while riding to prevent injuries.**

## Download INMOTION App



Download the App in the following ways

1. Scan the QR code on the left
2. Search "INMOTION" in the Apple store or Google Play Store.
3. Visit [www.inmotionworld.com/support/app](http://www.inmotionworld.com/support/app)

### **Note:**

The unicycle supports Bluetooth, with a BLE ID of: V11Y-XXXXXXXX, where XXXXXXXX represents the last 8 digits of the SN. Install the INMOTION App on your mobile device (iOS 12.1 and above or Android 7.0 and above supported) and follow the prompts to connect to your unicycle.

For more detailed features, download the latest version of the user manual from the official website of INMOTION App.

## Air Spring

Before using this product, please inflate the built-in air spring; otherwise, it may damage the product.

Prior to inflation, unscrew the red cap at the bottom of the footrest's air spring, then use the dedicated inflator provided with the product for inflation. Refer to the table below for the recommended air pressure. It is advisable to check the air pressure every three months.

### **Note:**

For instructions on how to check the air pressure of the top air spring after using it for a period of time, please scan the QR code to watch the video.

### Weight - Barometer

Weight	Air pressure
Under 60kg	80-120psi
60-70kg	120-130psi
70-80kg	130-150psi
80-90kg	150-180psi
90-100kg	180-200psi
100-130kg	200-220psi



Scan to check out the how-to video

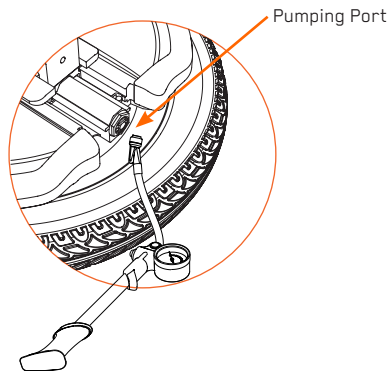
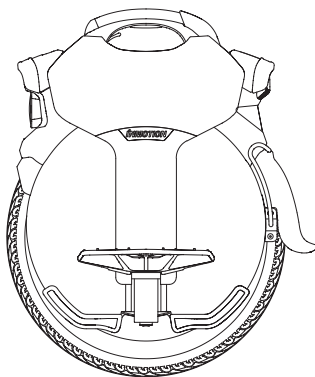

# LEARNING TO RIDE

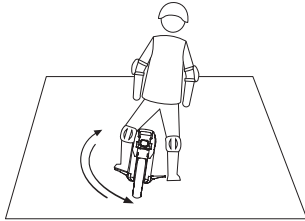

1. Step on the pedal with one foot, then swing back and forth.

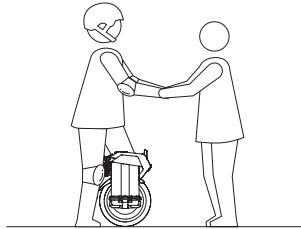

2. Step on the pedal with one foot, keep your feet and body upright and gradually shift your weight up.

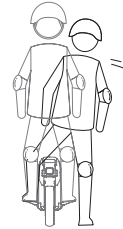

3. Step on the pedal with one foot, lift the other foot off the ground for 1-2 seconds and start gliding.

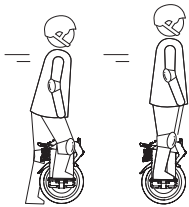

4. Step on the pedal with one foot, push back with the other foot and start gliding.

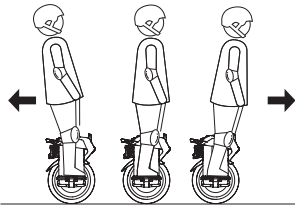

5. Step on pedals with both feet, use your weight to move forward and back.

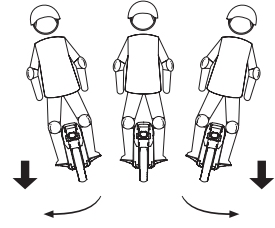

6. Press the pedals with feet by different force to make a turn.





INMOTION App



Facebook group



Website