

KUKirin S1 Max

OPERATION MANUAL



 www.kukirin.net

 service@kukirin.net

www.kukirin.net

KUKiirin S1 Max

Catalog in English.04

* Riding warning icons (See pages 04 - 17)

- | | |
|------------------------------------|------------------------------------|
| 1. WARNING | 2. PRECAUTIONS |
| 3. Packing list | 4. Schematic diagrams |
| 5. Assembly and operation guide | 6. Dash board and switch group |
| 7. Charging | 8. Riding precautions |
| 9. Potential safety risk avoidance | 10. Dangerous behavior prohibition |
| 11. Parameter list | 12. Maintenance and repair |
| 13. Troubleshooting | 14. Warranty and client support |
| 15. EC compliance declaration | |

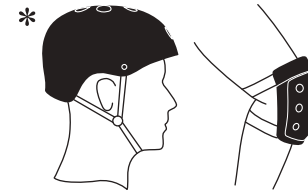

! Figure 1

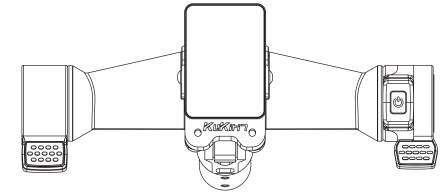

! Figure 2

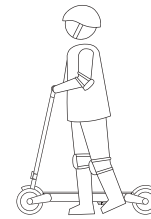

! Figure 3



! Figure 4



! Figure 5

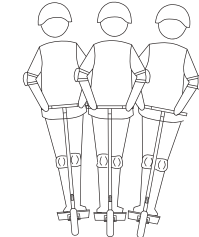

! Figure 6



! Figure 7

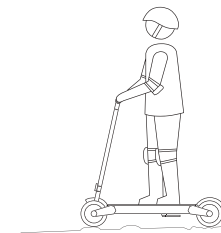

! Figure 8

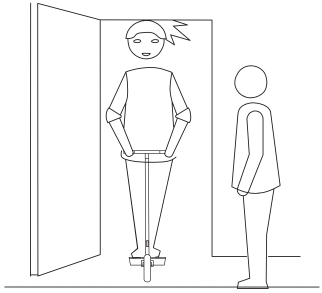

⚠ Figure 9

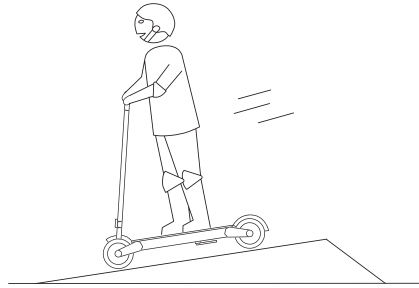

⚠ Figure 10

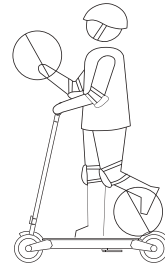

⊗ Figure 15

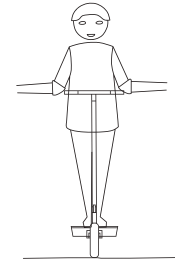

⊗ Figure 16

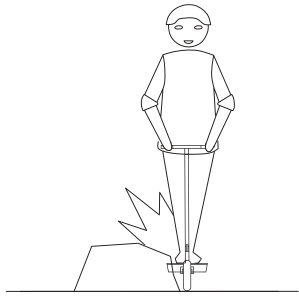

⚠ Figure 11

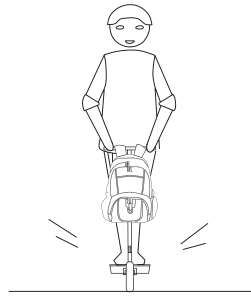

⚠ Figure 12

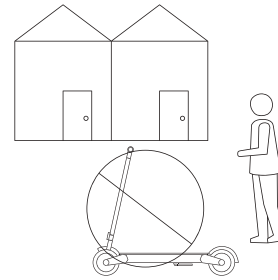

⊗ Figure 17

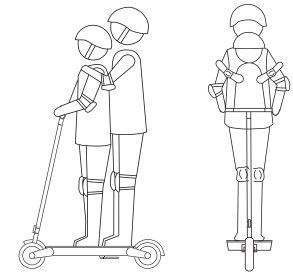

⊗ Figure 18

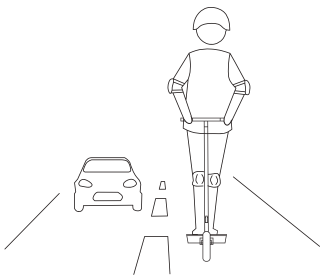

⊗ Figure 13

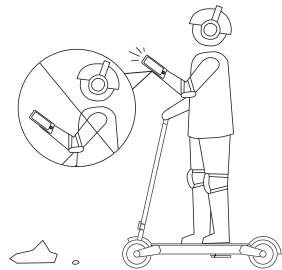

⊗ Figure 14

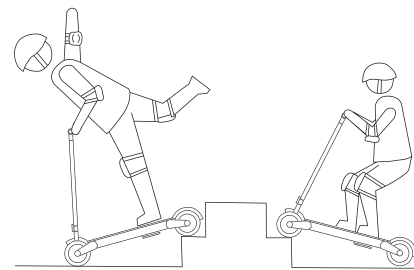

⊗ Figure 19

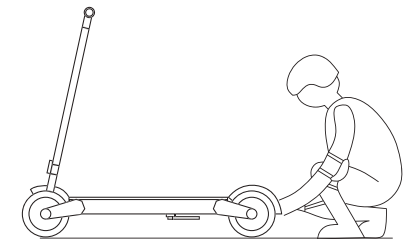

⊗ Figure 20

1. WARNING

Both this scooter and all of its components comply with all of the European safety laws and regulations. Nonetheless, we recommend that you should take protective measures and ride it responsibly. KUKIRIN will not be liable for any problem due to misuse of the product itself or failure in compliance with traffic regulations and the instructions herein.

It is of great importance for you to have a thorough understanding of your new electric scooter so that you can experience the best performance, comfort, enjoyment and safety while riding. To know this new scooter and its proper operation, you should read through this Manual first. The recommended minimum age of riders should be 16 years old; children aging from 0 to 16 years old are not suitable for this scooter, and children above 16 years old should ride this scooter under constant supervision. Maximum rider weight: 100 kg; the minimum and the maximum rider heights: from 120 cm to 200 cm.

It is very important for riders to ride this scooter in a safe and controllable manner for the first time because the faster the velocity is, the longer the braking distance will be. Please anticipate your trajectory and velocity while observing road rules, sidewalk rules and the most fundamental rules, and take a good care of yourself and others in all circumstances. For example, stay away from vehicles, obstacles and other cyclists while riding this scooter. No rider shall enter highways, motorways or public lanes, reverse their scooters or riding them in the rain. Please slow down and detour when encountering with waterlogged roads. Avoid heavily trafficked areas and crosswalks on foot. Please pay special attention to ensure your safety while riding this scooter at night. When approaching pedestrians or cyclists but they are not seeing or hearing you, please inform them of your presence in case of either scaring or surprising them.

Scooter belongs to vehicles with certain risks. For the sake of your own safety, please take your health and physical conditions into serious consideration in order to determine if there is any physical or health conditions that may pose a risk to your personal safety or prevent you from riding an e-scooter properly. Do not ride an e-scooter after drinking alcohol, taking drugs or having medicines not suitable for riding e-scooter. Do not ride an e-scooter in any hazardous area with flammable or explosive substances, liquids or dirt. Do not use cellphone or headphones while riding an e-scooter. Any load on the handlebars will compromise the scooter stability. It is necessary for you to know the traffic rules concerning e-scooter riding on local public roads, and you must observe these rules for each of your riding.

This e-scooter has no basic mandatory equipment upon shipment though such situation may vary among regions. As a result, if planning to ride this e-scooter on public roads, you must equip your e-scooter with basic mandatory equipment in accordance with relevant laws and regulations.

This product is designed for your personal use only. Do not apply it to any commercial or other purposes. Please preserve this Manual well for further reference.

All figures and pictures herein are for reference only. Please refer to the authentic product for details.

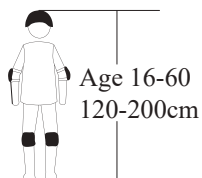

When riding a scooter, please wear protective equipment such as a helmet, knee pads, elbow pads, wrist guards, etc. At all times to reduce the risk of injury.

2. PRECAUTIONS

Please check the tire pressure before riding this e-scooter; its handlebars should be properly and securely installed. Please make sure that its battery have been fully charged. If its battery capacity becomes low during your riding process, please keep this e-scooter moving slowly and smoothly. Please charge your e-scooter as soon as possible.

Please check the charger, the cable and the plug before each charging operation. Do not use the charger if there is any damage. The braking distance on a wet road is usually longer than that on a dry road. As a result, riders have to brake as early as possible so as to realize a safer stop.

Cross protected passageways on foot. Avoid and eliminate all sharp edges arising from riding process. You shall try to avoid riding this e-scooter on a rainy, stormy or snowy day. Damp or flooded electrical modules (Control unit, engine and battery) may be subject to an irreversible damage and even result in battery explosion. This product can only be rode by one adult at one time. Please do not pick up any extra passenger. If you are uncomfortable or subject to alcohol or medicine, please do not ride this e-scooter.

Please do not conduct any acrobatic performance by this e-scooter because it is not designed for such performance. Do not refit or re-mold this e-scooter, including its steering tube, bushing, rod, folding mechanism, rear brake, etc. This vehicle is not a toy. As with any other vehicle, this scooter are subject to the probabilities of falling down, colliding or encountering with other dangerous circumstances. Do not lend your e-scooter to anyone without knowing how to ride it properly. If you allow others to ride your e-scooter, it is your responsibilities and liabilities to make sure: All of these riders have understood all of its warnings, precautions, instructions and safety precautions; they are able to operate this product in a safe and accountable manner; they can protect themselves and others from harm.

This e-scooter must be kept away from flammable materials and open flames. Do not ride this e-scooter in any rainy day.

3. Packing list

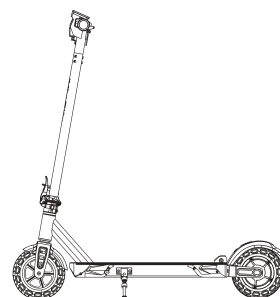

1. User Manual*1

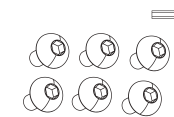

2. Toolkit and screw accessories

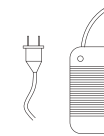

3. Charger*1

Please scrutinize them in case of any loss or damage. If there is, please contact us without delay.

4. Schematic diagrams

Note: Vehicle noise is less than 70 dB.

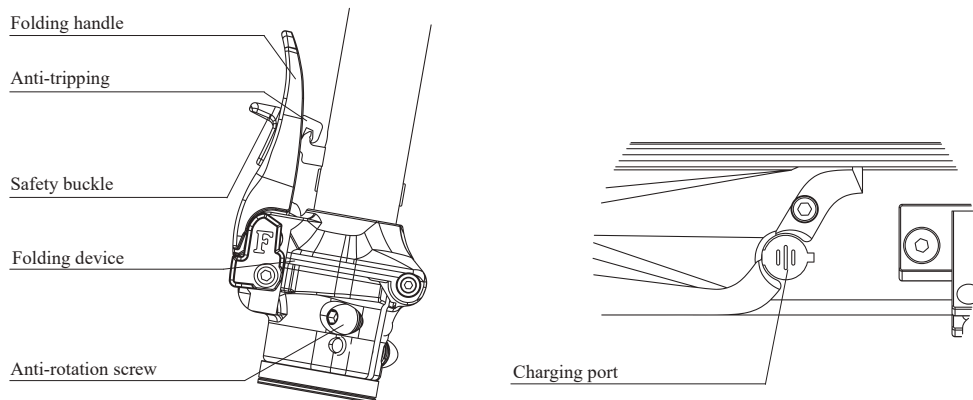
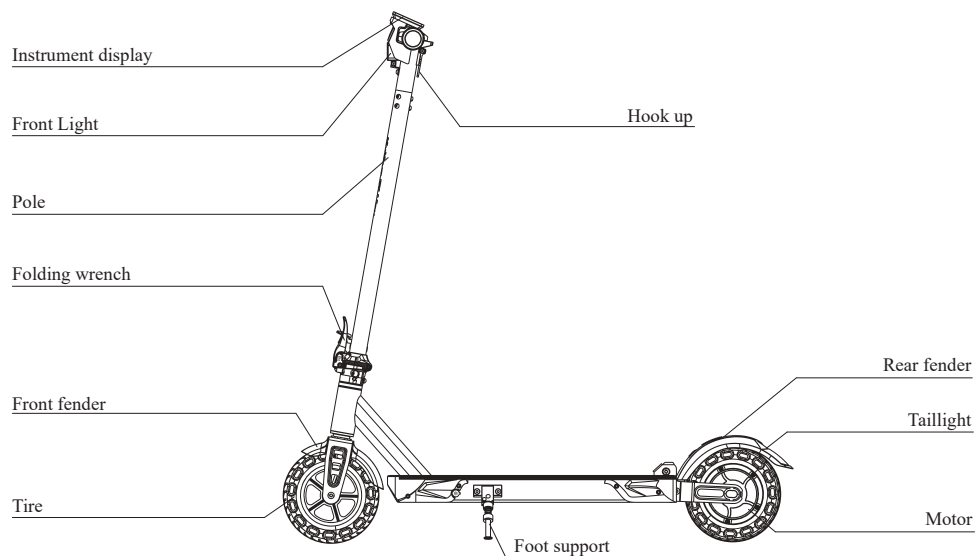

5. Assembly and operation guide

Unpacking and assembly

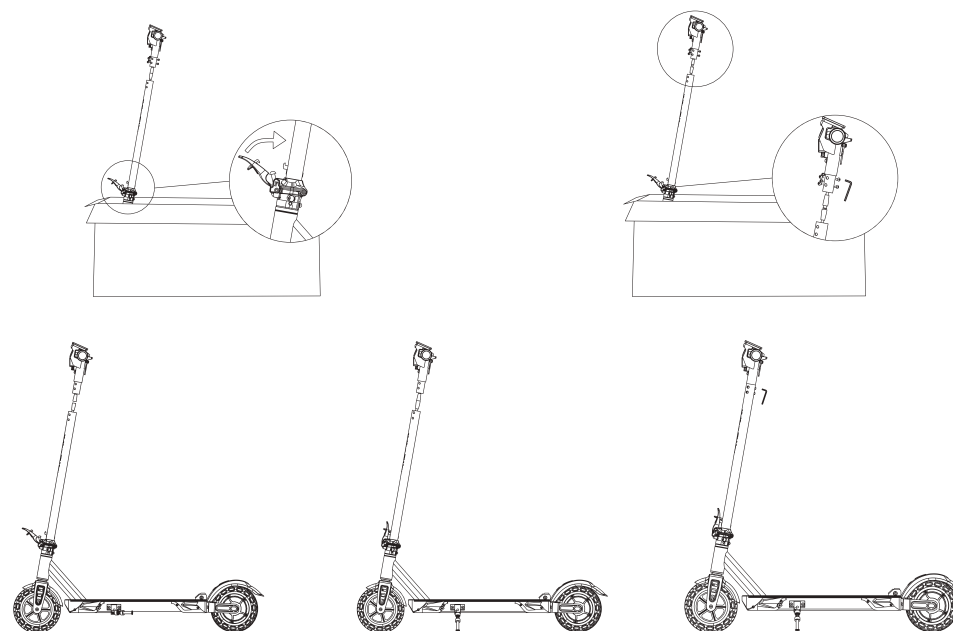

Folding and unfolding

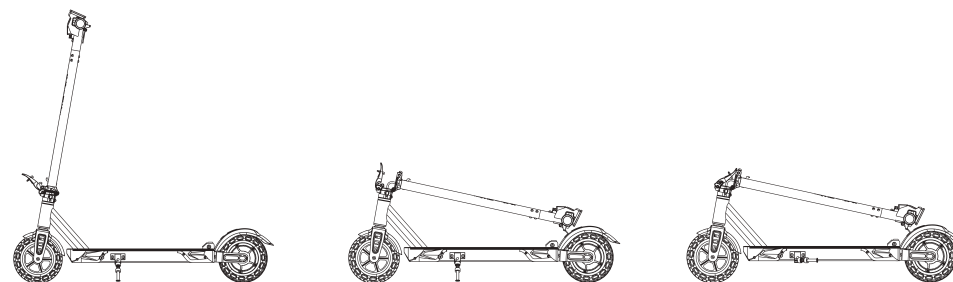

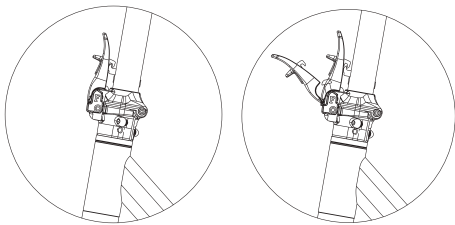
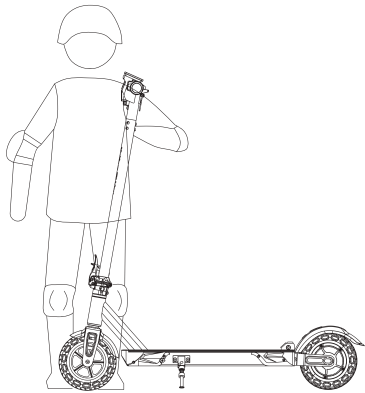

1. Slide the safety buckle to open the folding wrench.

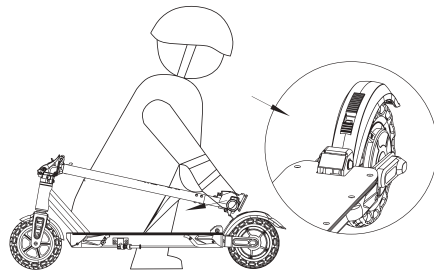

2. Fold the vehicle body and hook the hook into the corresponding position.

Transportation and parking

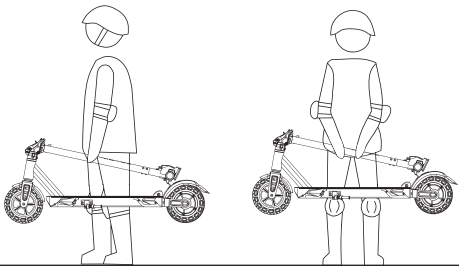

1. Lift the scooter with one or both hands.

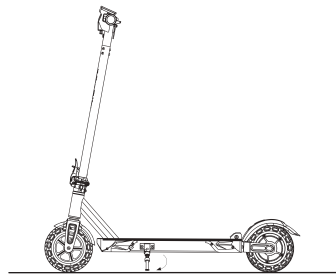

2. After riding the scooter, please release the kickstand and park it in the correct place.

6. Dash board and switch group

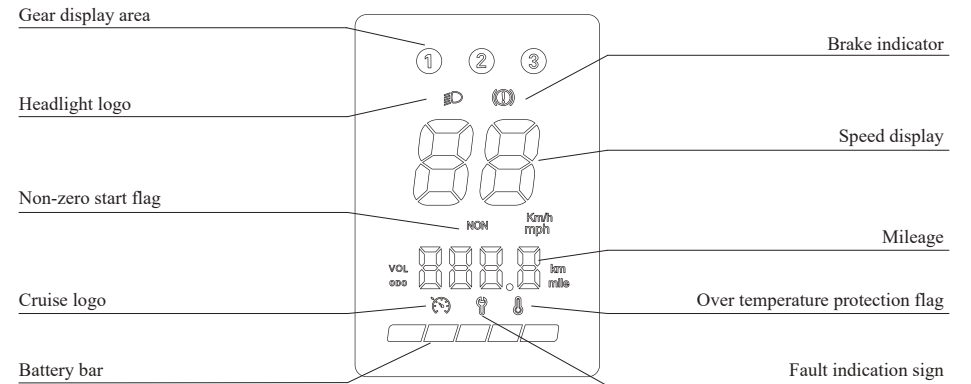
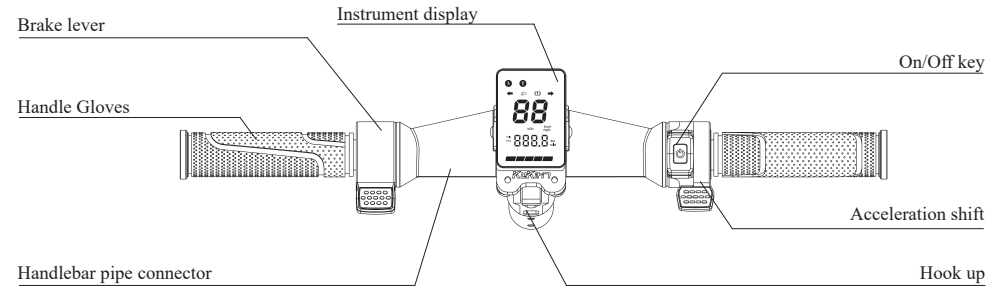

Icons	Names	Meanings
	Headlamp indicator	The icon lights up and indicates that headlamp is on.
	Velocity	The panel indicates the current scooter velocity.
	Brake Indicator	The icon lights up, indicating that the brake is activated.
	Gear	The panel indicates the current scooter velocity gear.

7.Charging

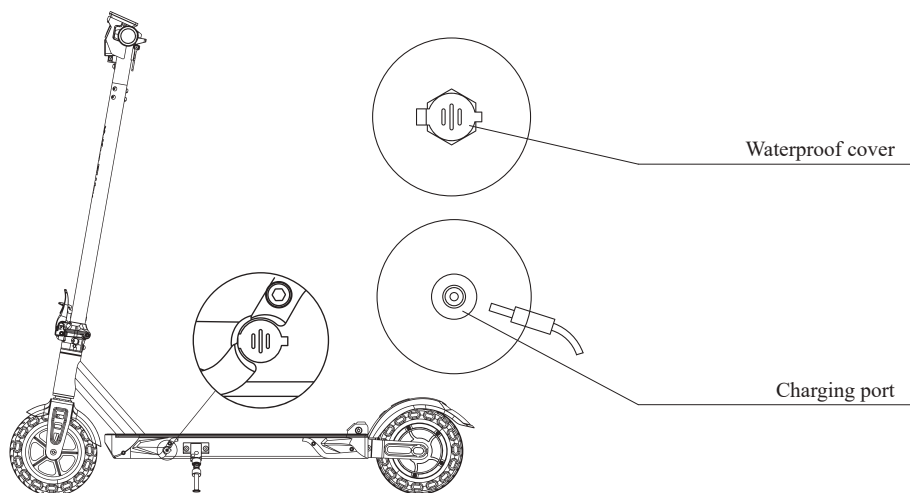







- ⚠ **Warm tips:** The charger indicator is in red during its charging process, and it will turn green after it is fully charged. Please charge the battery to its maximum capacity before the first utilization. you are suggested to charge the battery after each use and before it is used up. An excessively low voltage may shorten the service life of battery.
- ⚠ **Important prompts:** Please only adopt the original charger provided by KuKirin, rather than any other charger, to charge this scooter. The scooter must be turned off during the charging process. Plug the charger into a power socket ranging from 100 V to 240 V so as to charge the battery at a room temperature ranging from 0°C to 35°C.
- ⚠ Do not burn the battery or expose it to a high temperature because it may explode. Do not charge the scooter via a charging port, charger or power socket in a humid environment. Once the battery gets damaged or comes into contact with water, do not charge or continue using the battery. A battery under extreme conditions may leak. If the leakage should come into contact with skin, please rinse it immediately with soap water; if the leak should get into eyes, please rinse them immediately with pure water for at least 10 minutes and simultaneously seek for medical aid.
- ⚠ Do not refit the charger in any way. Prevent the battery away from small metal objects, such as paper clip, coin, key, nail or screw. Avoid swallowing the battery cells by mistake. If they are swallowed, please seek medical aid at once.
- ⚠ The battery must be embedded in the correct position. If the scooter is in idle for a long time, the battery shall be removed. Please tighten the rubber plug in the charging port when the scooter is not being charged. A scooter under charging shall not be rode.

8.Riding precautions









- ⚠ **ATTENTION:**
 - Do not exceed the maximum load bearing capacity of the scooter (Please refer to technical specifications).
 - Footwear requirement: Rider must always wear shoes when riding this e-scooter.
 - Compliance: Check and observe the local regulations concerning e-scooter riding.
- ⚠ **Driving:**
 - Insert and rotate the key, and press and hold on to the power button for three seconds to start the e-scooter.
 - Stand on its foot board with one foot in front and the other foot on the ground. Push the e-scooter forward gently and then press the throttle to speed up. Slow down or stop the e-scooter by brake rod.
- ⚠ **Braking method:**
 - Gently pinch the brake rod to slow down the e-scooter gradually so as to avoid a sudden braking.
 - Please start braking in advance since the braking distance will extend in wet and slippery weather conditions.
 - Combine braking and deceleration to control the e-scooter velocity and ensure your safe driving.
- ⚠ **Avoid obstacles:**
 - Avoid jumping over those many obstacles, such as curbs or steps, in urban traffic conditions.
 - Judge in advance and adjust the moving trajectory and velocity according to the shape, height or slippery degree of obstacle and keep a certain space away from pedestrians when crossing an obstacle.
 - When the obstacle becomes dangerous due to its shape, height or slippery degree, riders are recommended to get off and push the e-scooter around the obstacle.
- ⚠ **Parking:**
 - Press the brake rod to gradually slow down and stop the vehicle, then stabilize the vehicle and release the kickstand.
 - Please turn off the power and remove the key after using the e-scooter.

9.Potential safety risk avoidance

- ⚠ Lleve casco y equipo de protección para evitar peligros. (See Figure 1 on page 01.)
- ⚠ Please make sure that all of the display functions on the dash board are working properly before riding the e-scooter. (See Figure 2 on page 01.)
- ⚠ When pushing the e-scooter forward, please use the throttle cautiously so as to avoid pressing it down to the bottom. (See Figure 3 on page 01.)
- ⚠ Keep the e-scooter well balanced during its starting and stopping process, and pay attention to a safe starting and stopping. (See Figure 4 on page 01.)
- ⚠ Keep yourself well balanced during your riding process, grip the handlebars and speed up in a smooth manner. (See Figure 5 on page 01.)

-  Turn the handlebars slowly and tilt your gravity center when making a turn so as to avoid a sharp turn. (See Figure 6 on page 01.)
-  E-scooter riding is not advisable in a rainy day or flood condition. (See Figure 7 on page 01.)
-  Avoid over-speeding on speed bumps and other bumpy roads. Slow down and bend your knees slightly to adapt to complicated road conditions better. (See Figure 8 on page 01.)
-  Be careful not to hit your head when passing through doors or collide with a tall object. (See Figure 9 on page 02.)
-  Please control your velocity when going downhill. (See Figure 10 on page 02.)
-  Avoid tires coming in contact with larger obstacles. (See Figure 11 on page 02.)
-  Avoid carrying heavy loads on the handlebars as it may compromise riding safety. (See Figure 12 on page 02.)

10. Dangerous behavior prohibition

-  Please observe the local laws and regulations during the riding process. (See Figure 13 on page 02.)
-  Do not use electronic devices while riding this e-scooter so as to avoid distraction. (See Figure 14 on page 02.)
-  Please do not ride this e-scooter with only one hand or foot. (See Figure 15 on page 03.)
-  No rider shall ever ride this e-scooter without holding the handlebars. (See Figure 16 on page 03.)
-  This e-scooter shall not be charged indoors. Please pay attention to the charging safety. (See Figure 17 on page 03.)
-  This e-scooter is designed for single person only. Do not pick up passenger or child. (See Figure 18 on page 03.)
-  Do not ride this e-scooter up or down stairs or attempt to jump over high obstacles. (See Figure 19 on page 03.)
-  Do not touch the disc brake immediately with your bare hands after riding in case of burns. (See Figure 20 on page 03.)

11. Parameter list

Product name	KUKITIN S1 Max	
Dimensions	Folded dimensions	1082*500*460mm
	Unfolded dimensions	1082*500*1100mm
Parameters	Maximum velocity	≤ 25 km/h
	Endurance mileage at a medium velocity	≤ 39 km
	Maximum slope	≤ 15°
	Shock absorber	Spring shock absorber
	Water-proof grade	IP54
	Brake	Power-off brake + auxiliary brake
	Display contents	Velocity, mileage, battery capacity, headlamp, etc.
	Lamp light	LED
	Frame materials	Iron frame
Motor	Voltage	36V
	Rated power	350W
	Peak power	500W
Battery data	Input voltage	100~240V/50~60Hz
	Voltage / capacity	36V/10.4Ah
	Charging duration	42V/1.5A charger, takes about 7 hours to charge.
Weight	Maximum load	100 kg
	Net weight	About 16 kg
Tire	Type	Solid honeycomb tire
	Dimension	8 inch

12. Maintenance and repair

E-scooter cleaning:

Clean the main frame with a soft and damp cloth. For persistent stains, apply toothpaste, scrub them repeatedly with toothbrush and wipe them with a soft and damp cloth.

! Do not clean your e-scooter with alcohol, gasoline, kerosene or other corrosive or volatile solvents as they may damage its exterior and interior structure. Spray via pressurized washer or hose is strictly forbidden. Before cleaning, make sure that this e-scooter is powered off and free of charging and its charging port is tightly sealed. Otherwise, the cleaning process may compromise its electronic elements or cause water into its battery.

! **WARNING!** Please stop operating this product if it is damaged. This e-scooter will be subjected to high stress and normal abrasion during utilization so the relevant components shall be overhauled in a timely manner according to the Manual. Worn or damaged components or those beyond service lives must be replaced in time so as to avoid riding risks.

Daily maintenance:

Make sure that both brakes are functioning properly.

Scrutinize the tightness of all screws and nuts.

Wipe this e-scooter surface with a clean cloth so as to prevent water from entering electronic elements.

Battery maintenance:

When charging this e-scooter or leaving it in idle, please turn off its power and avoid full discharge.

When leaving this e-scooter in idle for a long term, please store it in a safe place. Keep its battery capacity above 50% and charge it at least every 3 months. Avoid using and storing its battery at an extreme temperature.

Charge this e-scooter via its original charger and avoid battery damage or fire risks.

Regular overhauling:

Scooter frame, front fork and suspension: Check scooter frame, front fork and suspension components (If any) regularly so as to ensure that there is no damage.

Monthly overhauling is recommended. Especially when it is rode frequently. Refill a small amount of white lubricant grease or oil into its folding mechanism for maintenance for every six months.

Storage:

Please store the vehicle in a flat, stable, well-ventilated and dry venue.

Avoid exposing this e-scooter directly to sunlight or in other excessively humid places for a long term. Keep this e-scooter clean.

WARNING! Please place the vehicle packaging and various components in a rational order, and keep them out of the reach of children so as to avoid them from swallowing by mistake.

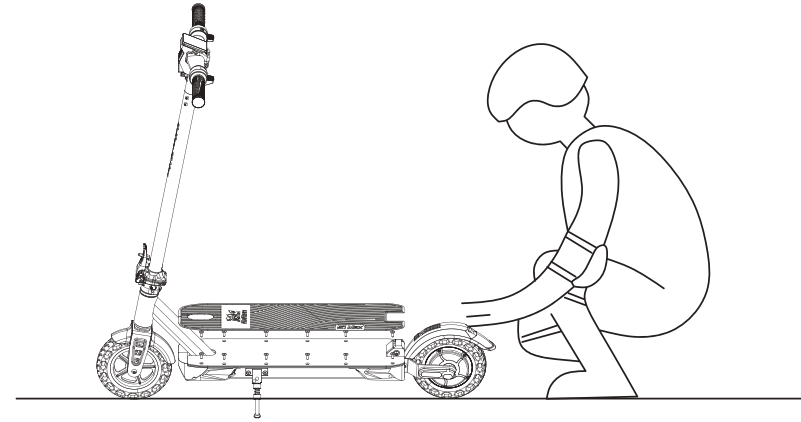

Replace the foot board grip:

When replacing the foot board grip, just replace it by removing the rubber pad on its surface.

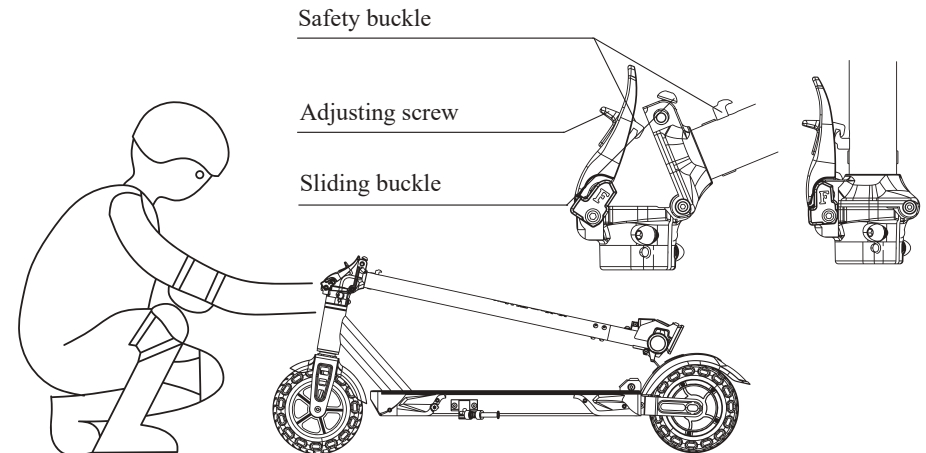

Shaky bracket adjustment:

First check whether the vertical tube screws are loose. If so, move the sliding buckle first, open the folding wrench, and then use the hexagonal wrench to adjust the adjustment screws to improve the shaking.

If this e-scooter wobbles due to multiple drops, such problem can be improved by adjusting the above-mentioned screws.

13. Troubleshooting

Malfunction	Code	Solutions
Motor hall fault	1E	Test the component after replacing the motor. If the fault remains after the motor is replaced, replace the controller and test it again.
Throttle fault	2E	Replace the throttle and try it again.
Controller failurez	3E	Replace the controller and try it again.
Brake failure	4E	Check if the white wire of the controller is firm and secure; otherwise, replace the brake handle and test it again.
Under-voltage	5E	The battery capacity is low. Please charge the battery and try it again.
Reception fault	6E	It belongs to a failure in instrument reception; replace the instrument / controller and try it again.
Transmission fault	7E	It belongs to a failure in instrument transmission; replace the instrument / controller and try it again.
Controller over temperature protection	9E	This fault occurs when the controller is in a high temperature state for a long time. Please check whether the controller is fixed and heat-dissipating well.

14. Warranty and client support

⊗ Prohibition: Do not adopt any accessory or additional item that are not approved by the manufacturer so as to avoid corresponding problems.

Warranty period:

If this product should fail or be damaged, it can be repaired, replaced or returned free of charge upon confirmation by Kuklin after-sales center. When applying, please contact the product dealer and conduct operation as per instructions. At that time, you need to produce accurate, complete and valid purchase information or invoice.

Customer service:

If component repair or replacement is necessary, please contact our authorized service center or dealer for support.

Warranty coverage:

Warranty contents	Warranty period
Controller, instrument, motor, lithium battery and charger, scooter frame, front body, rear wheel hub, brakes, folding mechanism, telescopic tube, front fork, brake system, throttle dial, etc.	1 year

15. EC compliance declaration

Manufacturer	Jinhua Feimi Intelligent Technology Co.,Ltd.
Address	No.14, South Mudan Street, Baiyang Street, Wuyi District, Jinhua City, Zhejiang Province, China
Description	Electric dual-wheel scooter, KUKIRIN
Additional information	S1 Max Electric Scooter
Declaración	<p>The contents concerning this declaration comply with the requests of the EU directives as follows:</p> <p>Comply with the Machinery Directive (2006/42/EC): EN 17128:2020;</p> <p>Comply with the Low Voltage Directive (2014/35/EU): EN 60335-1:2012+A11:2014+A13:2017+A1:2019 +A14:2019+A2:2019+A15:2021; EN 62233:2008.</p> <p>Comply with the EMC Directive (2014/30/EU): EN IEC 61000-6-1:2019; EN IEC 61000-6-3:2021 EN IEC 61000-3-2:2019+A1:2021; EN 61000-3-3:2013+A2:2021.</p> <p>Charger and power plug compliance test: EN 60335-2-29: 2004+A2:2010+A11:2018; EN 62233: 2008.</p>
Name	Mark Zhang
Company title	Director
Signature	<i>Mark Zhang</i>