



## xiaomi Mi Electric Scooter 3 User Manual

[Home](#) » [Xiaomi](#) » xiaomi Mi Electric Scooter 3 User Manual

xiaomi Mi Electric Scooter 3 User Manual



## Contents [ [hide](#) ]

- [1 Safety Instructions](#)
- [2 Product Overview](#)
- [3 Daily Care and Maintenance](#)
- [4 Personal Information Statement](#)
- [5 Copyright Statement](#)
- [6 Trademark Statement](#)
- [7 Product Statement](#)
- [8 Certifications](#)
- [9 Safety Warning](#)
- [10 Warranty Notice](#)
- [11 Disclaimer](#)
- [12 Documents / Resources](#)
- [13 Related Posts](#)

## Safety Instructions

- This appliance is not intended for use by persons (including children) with reduced physical, sensory or mental capabilities, or lack of experience and knowledge, unless they have been given supervision or instruction concerning use of the appliance by a person responsible for their safety.
- Children should be supervised to ensure that they do not play with the appliance.
- For the purposes of recharging the battery, only use the detachable supply unit provided with this appliance.
- This vehicle is a personal electric scooter with pure electric propulsion. The scooter is intended for riders older than 16 years. Do not ride the scooter if you suffer from reduced physical, sensorial or mental capabilities. Riders with a lack of experience or knowledge should drive carefully. Children should not play with the scooter or spare parts of it nor should cleaning or maintenance be done by children. The use of the machine results in the transmission of vibrations throughout the driver's body.
- Do not ride in traffic lanes or residential areas where vehicles and pedestrians are both allowed.
- This electric scooter is a leisure device. However, when entering a public area, it is considered a vehicle subject to possible risks. For your own safety, please follow the instructions in the manual as well as local traffic laws and regulations.
- At the same time, you should understand that risks cannot be entirely avoided as others may violate traffic regulations and drive incautiously, and you're exposed to road accidents just as when you're walking or biking. The higher the speed the longer the stopping distance. On a smooth surface, the scooter may slip, lose balance, and even result in a fall. Be cautious when riding, don't speed and keep a safe distance from other road users, especially when riding in unfamiliar areas.
- Respect pedestrians' Right of Way. Try not to startle them while driving, especially children. When you ride from behind pedestrians, ring your bell to give them a heads-up and slow your scooter down to pass from their left (applicable to countries where vehicles drive on the right). When you ride across pedestrians, keep to the right at a low speed. When you drive across pedestrians, keep the lowest speed or going off the vehicle.
- Closely follow the safety instructions in the manual especially in China and countries that lack relevant laws and regulations regarding electric scooters. Xiaomi Communication Co., Ltd. shall not be liable for any financial losses, physical injuries, accidents, legal disputes and other interest conflicts resulted from actions that violate user instructions.
- Riding with high speed or a speed that is not appropriate or adequate for the situation (bad weather conditions,

bad surface conditions, or the like) may lead into a potential loss of stability or loss of control. To reduce any risk, you must follow all instructions in this manual. Be careful when mounting and dismantling the product, it may fall and cause injury.

- Do not lend your scooter to whoever does not know the operations. And when you do lend it to your friends, please take the responsibility to ensure he/she knows the operations and wears the safety gear.
- Check the scooter before every use. Regularly check the tightening of the various bolted elements, in particular the wheel axles, the folding system, the steering system and the brake shaft. When you note loose parts, low battery alerts, flat tires, excessive wear, strange sounds, malfunctions and other abnormal conditions, stop riding immediately and call for professional support.
- Always park the scooter with kickstand on an even and stable surface. The scooter must be placed with the stand against the slope to prevent it from tipping over. Never place the scooter with the front facing down the slope, as the stand may close and tip the machine. Once the scooter is on its stand, check its stability to avoid any risk of falling (by slip, wind or slight jolt). Do not park the scooter in a busy area, but rather along a wall. If possible, always choose to park your scooter on flat ground.
- Wear a helmet, elbow pads and knee pads in case of a fall to avoid injury. Poor driving can lead to falls or serious accidents. Store the electric scooter indoors when not in use. Read the instruction manual and drive the electric scooter carefully. You should only operate the electric scooter after you have understood and applied all the safety rules. The scooter operator will be responsible for any damage or injury caused by failure to follow the instructions in the owner's manual. For a better driving experience, it is recommended to conduct a regular maintenance of the product. Please read the user material before charging the battery. DO NOT drive in rain or puddles. Required age of driver: 16 to 50 years. Not allowed for children.
- Do not touch the brake system, it could cause injuries due to sharp edges. The brake may become hot in use. Do not touch after use.
- To avoid inappropriate use, it is necessary to start coasting the scooter to activate the motor and the accelerator. When the scooter has stopped, the accelerator does not work.
- The A-weighted emission sound pressure level is less than 70 dB(A).
- The mechanical vibrations transmitted by the Scooter are less than 2.5 m/s<sup>2</sup>. The uncertainty of measurement: 1.5 m/s<sup>2</sup>.
- Accessories and any additional items which are not approved by the manufacturer shall not be used.
- To ride safely, you must be able to clearly see what is in front of you and you must be clearly visible to others.
- Keep plastic covering away from children to avoid suffocation.
- To prevent inappropriate use of the scooter, the rear wheel of the scooter must be locked with a padlock when parked.
- Traffic in the city has many obstacles to cross such as curbs or steps. It is recommended to avoid obstacle jumps. It is important to anticipate and adapt your trajectory and speed to those of a pedestrian before crossing these obstacles. It is also recommended to get out of the vehicle when these obstacles become dangerous due to their shape, height or slippage.
- Do not modify or transform the vehicle, including the steering tube and sleeve, stem, folding mechanism and rear brake.
- Eliminate any sharp edges caused by use.
- In all cases, take care of yourself and others.
- Do turn on the headlight and slow down the speed when you ride at night.
- Make sure the folding mechanism of your scooter is working properly before riding.
- Ensure that the battery is sufficient before riding. If not, please recharge it.

- When passing through a place designated for pedestrians who are entitled to the right-of-way laws like crosswalk, please get off to walk along with the scooter.

**WARNING!** Never use the product close to a water source.

**WARNING!** Stop using the product when damaged.

## Product Overview

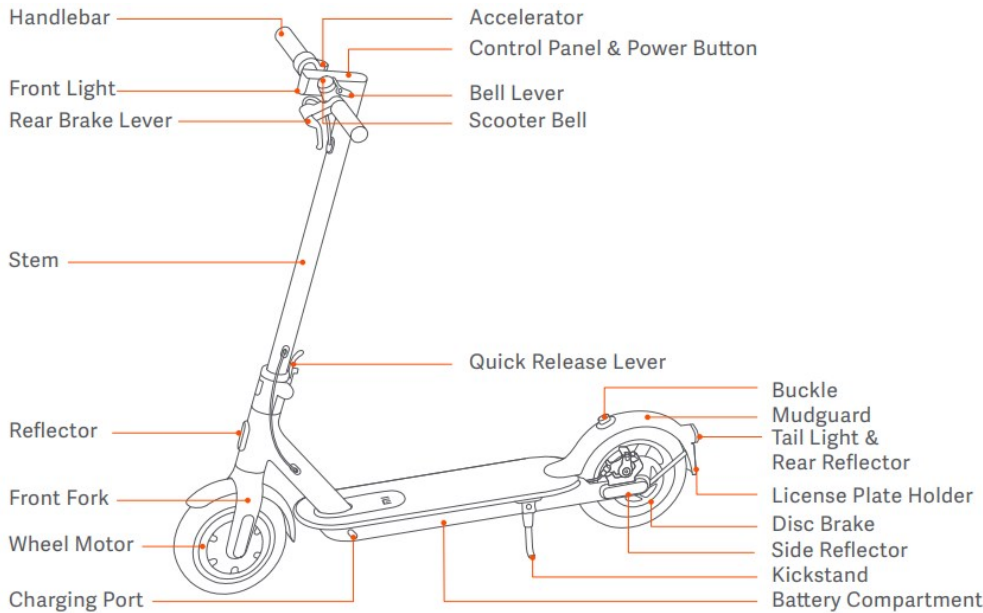

## Control Panel & Power Button

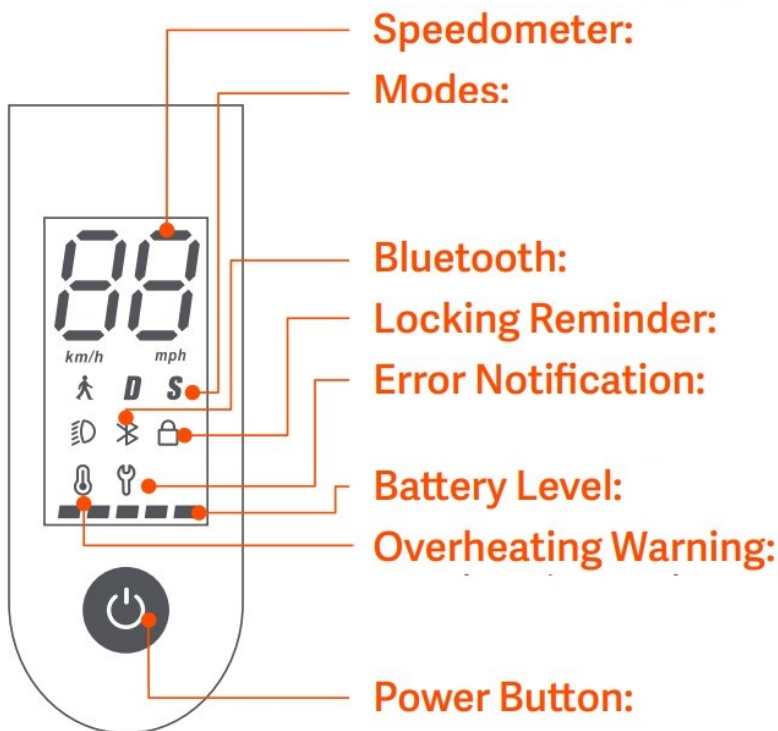

**Speedometer:** Display the current speed of the scooter, as well as to display error codes.

**Modes:** is for pedestrian mode (walking mode\*), the maximum speed of the scooter is 6 km/h, and the tail light is blinking in this mode (the headlight and the tail light are both on\*). D is for standard mode, and S for sport mode.

**Bluetooth:** The icon indicates that the scooter has been successfully connected to the mobile device.

**Locking Reminder:** Lock the scooter via the Mi Home/Xiaomi Home app.

**Error Notification:** When the wrench icon displays red, it indicates that the scooter needs repair. When the wrench icon blinks red, it indicates that the scooter has an error.

**Baery Level:** The baery power is indicated by 5 bars, each representing approximately 20 % of a full baery.

**Overheating Warning:** When the baery temperature has reached 50°C, the thermometer icon will be on. This will result in reduced acceleration and possibly charging issues. Immediately stop using or charging the scooter, and wait for its baery temperature to cool down. Once the baery temperature is within the normal operating temperature range, the scooter can be used or charged again.

**Power Buon:** Press the buon to turn the scooter on, and hold the buon for 3 seconds to turn the scooter off.

When the scooter is on, press the buon to turn on/off the headlight and tail light, and press twice to cycle through the modes.

## Daily Care and Maintenance

### Cleaning and storage

If you see stains on the scooter's body, wipe them off with a damp cloth. If the stains won't scrub off, put on some toothpaste, and brush them with a toothbrush, then wipe them off with a damp cloth.

**Notes:** do not clean the scooter with alcohol, gasoline, kerosene or other corrosive and volatile chemical solvents to prevent dire damage. Do not wash the scooter with a high-pressure water spray. During cleaning, make sure that the scooter's turned off, the charging cable is unplugged, and the rubber flap is closed as water leakage may result in electric shock or other major problems. When the scooter's not in use, keep it indoors where it is dry and cool. Do not put it outdoors for long time. Excessive sunlight, overheating and overcooling can accelerate tire aging and compromise the scooter and the baery pack's lifespan.

### Tire maintenance

Regularly check the tire pressure (at least every 2-3 months), the recommended tire pressure is 50 psi. The max. tire pressure is 60 psi. Riding with an incorrect tire pressure reduces tire life and safety

### Maintenance and removal of the baery

Do not remove the baery. Removing the baery is complicated and can alter the operation of the machine: You can contact an authorized repairer if the product is still guaranteed. If the product is not guaranteed you can contact any specialized repairer of your choice. You can ask for the list of the authorized repairers to the customer service available at [www.mi.com](http://www.mi.com). For any further question, you can contact the customer service available at [www.mi.com](http://www.mi.com). Spare tires supplied with the product are to be mounted on the wheel by a professional repairer. Removing the wheels is complicated and incorrect assembly can lead to instability and malfunctions:

- Please contact an authorized repairer if the product is still under manufacturer guarantee. You can ask for the list of the authorized repairers to the customer service available at [www.mi.com](http://www.mi.com).
- If the product is no longer under guaranteed you can contact any specialized repairer of your choice.
- Should you have questions, you can contact Xiaomi's customer service available at [www.mi.com](http://www.mi.com).
  1. Do not use baery packs of other models or brands, as there may be a safety risk.
  2. Do not disassemble, squeeze or puncture the product. Do not touch its baery contacts. Do not disassemble or poke the outer casing. Do not place the product into water or fire, nor expose it to temperatures above 50°C (including heat sources such as stoves, heatings, etc.). Avoid metal objects from touching the baery contacts, since this may result into short circuits, physical injury or even death.
  3. Any water going into the baery may cause damage to the internal circuit, risk of fire or even explode. If there is any suspicion of water going into the baery, immediately stop using the baery and return it to the aer-sales service for inspection.
  4. Improper disposal of used baeries can seriously pollute the environment. Observe local regulations when

disposing of this battery pack. Do not discard this battery pack at will, to protect the natural environment.

5. Fully charge after every use, in order to extend its battery life.

Do not place the battery in an environment where the ambient temperature is higher than 50°C or lower than -20°C (e.g., do not leave the scooter or the battery pack in a car under direct sunlight for an extended time). Do not throw the battery pack into fire as it may lead to battery failure, battery overheating, and even another fire. If the scooter is expected to be idle for more than 30 days, please fully charge the battery and place it in a dry and cool place. Keep in mind to recharge it every 60 days to protect the battery from potential damage which is beyond limited warranty. The scooter shall be only be used with original batteries and charging of the Scooter shall only be done by the original battery charger supplied with the scooter (or any compatible battery model or battery charger model approved by the manufacturer). Always charge before exhausting the battery to prolong the battery's lifespan. The battery pack performs best at normal temperature, and poor when it is below 0°C. For instance, when it is below -20°C, the riding range is only half or less at normal state. When the temperature rises, the riding range restores. For detailed information, please refer to Mi Home/Xiaomi Home app.

The external flexible cable of this battery charger cannot be replaced; If the supply cord is damaged, it must be replaced by a special cord or assembly available from the manufacturer or its service agent. Should you have questions, you can contact Xiaomi's customer service available at [www.mi.com](http://www.mi.com).

**Note:** fully charged scooter will last for 120-180 days. The built-in intelligent chip will keep a log of its charging and discharging records. The damage caused by prolonged no charge is irreversible and is beyond limited warranty. Once the damage is done, the battery cannot be recharged (non-professionals are forbidden to dismantle the battery pack, as it may cause electric shock, short circuit or even major safety accidents). In case of accident, blockage or breakdown, do not try to repair by yourself. Contact an authorized repairer if the product is still under guarantee. If not, you can contact any specialized repairer of your choice. You can ask for the list of the authorized repairers to the customer service available at [www.mi.com](http://www.mi.com). For any question, please contact Xiaomi's customer service available at [www.mi.com](http://www.mi.com). Efforts have been made to simplify wording in the user material for users. When an action appears too complicated for a user, he is advised to contact an authorized or a specialized repairer or Xiaomi's customer service.

**WARNING!** As with any mechanical component, a vehicle is subject to high stresses and wear. The various materials and components may react differently to wear or fatigue. If the expected service life for a component has been exceeded, it may break suddenly, therefore risking causing injuries to the user. Cracks, scratches and discoloration in the areas subject to high stresses indicate that the component has exceeded its service life and please contact an authorized or a specialized repairer or Xiaomi's customer service.

## Adjust the stem

Before adjustment, make sure the scooter is powered off and not charging.

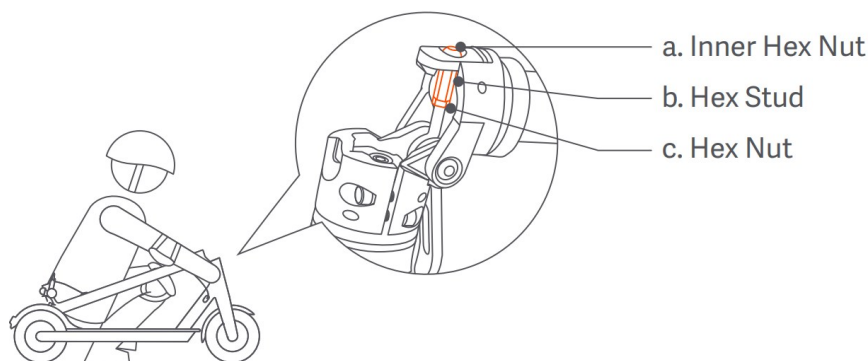

Long-term use of the scooter may result in loose screws, causing the stem to get unstable. If you notice the stem gets shaky when riding, follow the steps below.

### Tools:

1: 8-10 mm wrench

**II:** 4 mm Allen key

**Note:** These tools are to be prepared by the user.

**Steps:**

1. When in the folded state, use tool I to loosen “c” (clockwise).
2. Use tool I to loosen “b” (clockwise).
3. Use tool II to adjust “a” (clockwise) to the appropriate position, and use tool I to tighten “b” (counterclockwise).
4. Fold the stem up, close the quick release lever.
5. Shake the stem to see if the problem has been resolved. If not, repeat step 2 and 3. If it has, continue to step 6.
6. Return the scooter to the folded state and use tool I to tighten “c” (counterclockwise). Step 6 is mandatory.

**Personal Information Statement**

**Scope of personal information**

You agree that we may collect the following personal information when you register in the Mi Home/Xiaomi Home app (the app): name, gender, age, date of birth, ID number, address, contact information, hobbies, occupation, emergency contact, account information, and the time and location information of your usage of our service. You are providing the above information on a voluntary basis.

**Collection and processing of personal information**

The ultimate purpose for us to collect your personal information through the app is to provide you with beer products and services and to improve and optimize your user experience. The specific collection methods and channels include, but not limited to:

1. Membership registration;
2. Questionnaire;
3. Aer-sales tracking and return visits;
4. Soliciting of comments or suggestions on products or services;
5. Organization of events and soliciting of participants. You have the right to refuse to provide your personal information. However, if you refuse to provide certain personal information, you may not be able to use the products and services provided by us, or your use of such products or services may be affected.

**Use and disclosure of personal information**

1. You agree that your personal information may be used and disclosed (including being stored and processed) in the following ways: used by us (including our branches); disclosed by us to our affiliated companies for their use; disclosed by us and our affiliated companies, within their respective normal business scopes, to and used by their respective assignees or successors, legal and financial advisers, external suppliers, and agents.
2. We and our affiliated companies may send you information about products, services, and activities. You agree to receive the aforesaid information.
3. We may disclose your personal information to a third-party other than those mentioned above under any of the following circumstances or for any of the following purposes:
  - upon your special authorization;
  - for compliance with mandatory requirements of laws or government authorities (including judicial

authorities);

- for performance of applicable service clauses (including investigations of possible violations);
  - for identifying, preventing, or handling issues relating to fraud, security, or technology;
  - to the extent required or permitted by the law, to protect the rights, interests, property, or safety of users or the public against damage;
  - disclosed to and used by your emergency contact in an emergency.
4. The personal information may be transferred and stored by electrical means. The recipients and/or users of the aforesaid information and their servers may be located within or outside China.
  5. We will protect the security of your personal information. We will adopt security technologies and procedures and other measures to protect your personal information against unauthorized access, use, or leaks. We will also cause the recipients and users stated herein to undertake to protect and keep confidential your personal information.
  6. You agree to exempt the recipients stated herein and/or users of the personal information from all claims, liabilities, or losses that arise or may arise with respect to information disclosure and use according to the clauses herein, unless such claims, liabilities or losses are directly caused by willful misconduct or gross negligence of the recipients and/or users.
  7. We will keep your personal information for a period not longer than the period necessary for the intended purpose of collecting such information, or the period specified in any contract or applicable law.
  8. For details about collection, storage and use of user data, see the privacy policy of Xiaomi Inc. at [www.miui.com/res/doc/privacy/cn.html](http://www.miui.com/res/doc/privacy/cn.html).

## Copyright Statement

We reserve all rights associated with the All texts, images, photos, audios, animations, videos, layout designs, and other intellectual properties are under legal protection. They may not be reproduced for commercial use or distribution, or be used on other sites or apps aer modification.

## Trademark Statement

is the trademark of Xiaomi Inc. All rights reserved. Ninebot is a registered trademark of Ninebot (Tianjin) Technology Co., Ltd., all other trademarks and trade names are those of their respective owners. All the described functions and instructions were up to date at the time of printing this manual. However, the actual product may vary due to improved functions and design.

Manufactured for: Xiaomi Communications Co., Ltd.

Manufactured by: Ninebot (Changzhou) Tech Co., Ltd.

**Address:** 16F-17F, Block A, Building 3, No.18, Changwu Mid Rd, Wujin Dist., Changzhou, Jiangsu, China.

## Product Statement

Familiarity with the scooter makes riding easier. So, please kindly note that:

1. Read the scooter user material carefully before riding the vehicle.
2. Do not allow anyone who has not read the scooter user material to use your scooter.
3. Correctly install all parts as instructed in the user manual. Improper installation may lead to loss of control, collisions, and falls. Turn off the power before installation and maintenance. To avoid accidents when riding the scooter, make sure bolts and screws are tightened. Tighten all parts properly. If the parts are too loose or too tight, it may cause vehicle damage or malfunction.



4. Do not charge the product when the socket is wet. To charge the product, insert the power cable into a correct socket (200-240 V/50-60 Hz), and keep it away from children, pets, and flammable materials.
5. Do not place the battery in an environment where the ambient temperature is higher than 50°C (122°F) or lower than -20°C (-4°F).
6. Do not use the battery if it is damaged, has a strange odor, emits smoke, or gets overheated. Keep a leaking battery away from other objects.
7. Do not try to open or dismantle the batteries and damaged supply cord because they contain hazardous materials inside. If the supply cord is damaged, contact our aer-sales support department if you are in doubt.
8. Recharge the scooter in time to avoid damaging the battery. A fully charged scooter can remain on in standby mode for about 120 to 180 days while an undercharged scooter can remain on in standby mode for about 30 to 60 days.
9. **WARNING:** Do not use a charger from any other product. Keep a safe distance from the surrounding combustibles when charging.
10. Do not press or knock the battery and avoid serious drops or strong vibration of the battery. If these conditions occur, or liquid infiltrates into or splashes into the product, it may cause damage to the battery or circuit or short circuit. Stop using immediately and dispose of properly.
11. Ask your dealer or customer service for training materials. Familiarize yourself with the scooter before riding outdoors. The more you practice, the safer you will be when riding in a new environment. Remember the following essentials: Start with the basic exercises like going forward, turning, stopping in open places without barriers ( $\geq 10 \text{ m} \times 10 \text{ m}$ , or  $32.8 \times 32.8$ ), and keeping your body relaxed. It is advisable for you to practice for the first time under instructions of an experienced user or a coach. When you have mastered the basic skills, practice riding through narrow areas, and then turning and stopping. After you can precisely control the vehicle in narrow spaces and on various surfaces, you can start to ride on roads. If your scooter is updated, start again with the basics.
12. Examine the scooter every time before you ride it. Ensure that there are no loose or damaged parts.
13. Look around before and during riding and braking to avoid injury, damaging the surrounding environment, or injuring others.
14. Ensure that the tire pressure is within the range specified in the parameter table. Overly high pressure will raise the risk of loss of control, collisions, and falls. Too low pressure will damage the tire.
15. Check the tire pressure at least twice a month or every time you ride long distance to avoid instability, accidents, and tire damage.
16. If the tire becomes loose, stop riding immediately and check the tire.
17. Check the tightness of the brake line regularly to avoid the risk of the brakes being out of position or malfunctioning due to loose brake lines. You bear the damage caused by improper maintenance.
18. Step on the scooter from either side and wear professional protective gear.
19. Always wear shoes. Never ride barefoot, in high-heels or sandals when riding the scooter.
20. Do not immerse the battery or vehicle in water. Avoid heavy or lengthy exposure to rain and do not clean the vehicle with high pressure water as water may get into the charging port. If your scooter has already been exposed to rain, use a soft, dry cloth to wipe it down. Stop using the vehicle immediately and contact the aer-sales service. Do not perform other operations except wiping the body, because improper care and cleaning will void the warranty.
21. Braking performance and friction between the tire and road deteriorates in wet conditions, so it is harder to control the speed and easier to lose control. Slow down and brake early when it is wet weather.

22. Recharge the battery when the low-battery icon is displayed because the scooter may not have adequate power to maintain a high-speed riding.
23. Keep vigilant at all times even if it is easy for you to ride the scooter. Do not go over obstacles or ride on rugged or wet roads, loose surfaces, or slopes.
24. Watch out for surface changes on roads and grass.
25. Be careful when turning and do not turn too fast.
26. Do not take the risk of riding on steep slopes, rugged surfaces or other surfaces that you did not encounter before.
27. Do not ride on motorways. Obey the traffic rules, let pedestrians go first, and never run a red light.
28. Respect the rights of motorcycle drivers, cyclists, pedestrians and other people.
29. Take precautions during riding and be aware of your safety, traffic and pedestrians. Avoid high traffic areas or overcrowded areas.
30. In any case, anticipate your trajectory and your speed while respecting the code of the road, the code of the sidewalk and the most vulnerable. Be prepared to respond to any of these dangers: vehicles decelerating or turning in front of or behind you; opening car doors; people crossing the road; children and pets near the road; and distractions like potholes, manhole covers, rail lines, construction, debris, and so on.
31. Ride on designated cycle tracks or the road edge if possible. Go in a direction allowed by traffic regulations or that specified by local government and laws.
32. Stop when you see a stop sign or at traffic lights. Get off slowly and watch the traffic. Please keep in mind that there is a risk of colliding with other vehicles when you are riding the scooter. Allow automobiles to go first even when you are riding on your dedicated path.
33. Do not seek thrills by holding onto other vehicles to get pulled along.
34. This vehicle is not intended for acrobatic use.
35. Do not ride in bad weather, low visibility, or under intense physical exertion.
36. Do not ride alone in remote areas. Even when you are accompanied by someone else, ensure that people know your destination and the time you expect to return.
37. Be aware of the height added by your helmet and by standing on your scooter. Be careful when you ride indoors, through doorways, or in other low-height places.
38. Do not wear loose clothing that might get trapped in the wheel.
39. Wear protective eyewear when riding to protect your eyes against dirt, dust, and insects. Use darker lenses when it is bright and clearer lenses when it is dim.
40. Do not carry passengers or children.
41. The scooter is not a medical instrument. Do not ride the scooter if you cannot get on or off the vehicle without assistance.
42. Do not ride the scooter on stairs, in elevators, or through revolving doors.
43. Do not ride the scooter in low visibility conditions.
44. Do not ride the scooter on highways unless it is allowed by law.
45. Do not divert the use of scooter, such as to transport cargo.
46. Slow down and give way to pedestrians, bicycles, and automobiles when approaching or passing through crossroads, motorways, corners, and gates.
47. Remain vigilant when you ride the scooter as you do with another means of transport. Do not ride the scooter when you are ill or under the influence of alcohol or drugs.
48. Do not use your phone or perform other tasks when riding because you need to be aware of your surroundings

all the time.

49. Note that the scooter is designed for people between the ages of 16-50. Parents are advised not to allow their minor children to ride the scooter.
50. Do not make emergency stops, especially on smooth surfaces, to avoid skidding and falling.
51. The vehicle may slide if it is parked and powered on, so turn the power off when you park. Do not park the scooter in no-parking areas, such as emergency exit and fire escape.
52. In summer, store the scooter in a safe place where the temperature is below 45°C (133°F). Do not leave it under direct sunlight for an extended time.
53. In winter, store the vehicle in a safe place where the temperature is not lower than -20°C (-4°F). After storing the vehicle in sub-zero temperatures, move it to and place it in a place with room temperature for at least half an hour before charging it.
54. Do not modify the scooter.
55. Know and comply with the law in the place you ride the scooter.
56. If your scooter needs repair or test, has errors or malfunction, or if you need to replace vehicle parts, contact our after-sales support department if you are in doubt.
57. The data and parameters of the scooter vary with models, and are subject to change without notice.
58. Any load attached to the handlebar will affect the stability of the vehicle.
59. Switch off the vehicle or into a certain non-operational mode during charging.
60. The scooter shall be used only for one person.

This statement is governed by the laws of the People's Republic of China.

We shall not be liable to any customer for any claims, responsibilities or losses arising from or as a consequence of the customer's violation of the preceding provisions. Riders shall be responsible for any unforeseen or unavoidable risks during riding. You may choose to accept the preceding provisions and start to use the product, or not to accept the preceding provisions and return the product. You must keep the returned product and its package in a condition that does not affect resale of the product. To resell your scooter, remember to hand this Legal Statement together to the buyer, because it is a statutory part of the vehicle. If you have any questions, please feel free to contact us. Thank you again for choosing our products.

## Certifications

European Union Compliance Statement

Battery recycling information for the European Union



Batteries or packaging for batteries are labeled in accordance with European Directive 2006/66/EC and amendment 2013/56/EU concerning batteries and accumulators and waste batteries and accumulators. The Directive determines the framework for the return and recycling of used batteries and accumulators as applicable throughout the European Union. This label is applied to various batteries to indicate that the battery is not to be thrown away, but rather reclaimed upon end of life per this Directive. In accordance with the European Directive 2006/66/EC and amendment 2013/56/EU, batteries and accumulators are labeled to indicate that they are to be collected separately and recycled at end of life. The label on the battery may also include a chemical symbol for the metal concerned in the battery (Pb for lead, Hg for mercury, and Cd for cadmium). Users of batteries and accumulators must not dispose of batteries and accumulators as unsorted municipal waste, but use the collection framework available to customers for the return, recycling, and treatment of batteries and accumulators. Customer participation is important to minimize any potential effects of batteries and accumulators on the environment and human health due to the potential presence of hazardous substances. Before placing electrical and electronic equipment (EEE) in the waste collection stream or in waste collection facilities, the end user of equipment containing batteries and/or accumulators must remove those batteries and accumulators for separate collection

## Waste Electrical and Electronic Equipment (WEEE) Directive



“All products bearing this symbol are waste electrical and electronic equipment (WEEE as in directive 2012/19/EU) which should not be mixed with unsorted household waste. Instead, you should protect human health and the environment by handing over your waste equipment to a designated collection point for the recycling of waste electrical and electronic equipment, appointed by the government or local authorities. Correct disposal and recycling will help prevent potential negative consequences to the environment and human health. Please contact the installer or local authorities for more information about the location as well as terms and conditions of such collection points”.

## Restriction of Hazardous Substances Directive (RoHS)

This Ninebot (Changzhou) Tech Co., Ltd. product, with included parts (cables, cords, and so on) meets the requirements of Directive 2011/65/EU on the restriction of the use of certain hazardous substances in electrical and electronic equipment ( “RoHS recast” or “RoHS 2” ).



## Radio Equipment Directive

Certification Experts B.V. Amerlandseweg 7, 3621 ZC Breukelen, The Netherlands This device meets the EU requirements on the limitation of exposure of the general public to electromagnetic fields by way of health protection. Hereby, [Ninebot (Changzhou) Tech Co., Ltd.] declares that the radio equipment type: [DDHBC16NEB] , [DDHBC18NEB], [DDHBC24NEB] are in compliance with Directive 2014/53/EU. The full text of the EU declaration of conformity is available at the following internet address:

<http://www.mi.com/global/service/support/declaration.html>.



## UK-REP:

UKCA Experts Ltd. Dept 302, 43 Owston Road Carcro, Doncaster, DN6 8DA United Kingdom Hereby, [Ninebot (Changzhou) Tech Co., Ltd.] declares that the radio equipment type [DDHBC16NEB] is in compliance with the Radio Equipment Regulations 2017, Supply of Machinery (Safety) Regulations 2008 and the Restriction of the Use of Certain Hazardous Substances in Electrical and Electronic Equipment Regulations 2012. The full text of the UK declaration of conformity is available at the following internet address:

<https://www.mi.com/uk/service/support/declaration.html>

## Safety Warning



### CAUTION

Danger! Read user manual before use.



### CAUTION

Hot Surface! Do not touch the surface near this symbol.



### CAUTION

Sharp Edges. Do not touch the sharp edges or corner.



### CAUTION

Do not disassemble baery cover, hazardous energy inside.

## Warranty Notice

As a Xiaomi consumer, you benefit under certain conditions from additional warranties. Xiaomi offers specific consumer warranty benefits which are in addition to, and not instead of, any legal warranties provided by your national consumer law. The duration and conditions related to the legal warranties are provided by respective local laws. For more information about the consumer warranty benefits, please refer to Xiaomi's official website <https://www.mi.com/en/service/warranty/>. Except as prohibited by laws or otherwise promised by Xiaomi, the after-sales services shall be limited to the country or region of the original purchase. Under the consumer warranty, to the fullest extent premised by law, Xiaomi will, at its discretion, repair, replace or refund your product. Normal wear and tear, force majeure, abuse or damage caused by the user's negligence or fault are not warranted. The contact person for the after-sale service may be any person in Xiaomi's authorized service network, Xiaomi's authorized distributors or the final vendor who sold the products to you. If in doubt please contact the relevant person as Xiaomi may identify. The present warranties do not apply in Hong Kong and Taiwan. Products which were not duly imported and/or were not duly manufactured by Xiaomi and/or were not duly acquired from Xiaomi or a Xiaomi's official seller are not covered by the present warranties. As per applicable law you may benefit from warranties from the non-official retailer who sold the product. Therefore, Xiaomi invites you to contact the retailer from whom you purchased the product.

## Disclaimer

The user material is published by Xiaomi or its local affiliated company. Improvements and changes to this manual necessitated by typographical errors, inaccuracies of current information, or improvements to programs and/or equipment, may be made by Xiaomi at any time and without notice. Such changes will, however, be incorporated into new online editions of the user material (please see details at [www.mi.com/global/service/userguide](http://www.mi.com/global/service/userguide)). All illustrations are for illustration purposes only and may not accurately depict the actual device.

## Documents / Resources

	<p><a href="#">xiaomi Mi Electric Scooter 3</a> [pdf] User Manual Mi Electric Scooter 3, Electric Scooter 3, Scooter 3, Mi Electric Scooter, Electric Scooter, Scooter</p>
---	--