

iENYRID ES1

iENYRID
enjoy your ride

USER MANUAL

PLEASE READ THE INSTRUCTIONS CAREFULLY BEFORE RIDING

iENYRID



Scan QR Code Or Enter URL for Online Installation Video

<https://www.youtube.com/watch?v=qwRXEEPZNn4>



Read This Manual Before Using

Why Is It Necessary To Read This Manual Before Operating?

- 1、 This manual was written to help you understand the proper use and maintenance of the iENYRID line of Electric Scooter.
- 2、 It is important to understand the functions and features of the new iENYRID before operating it as it will allow you to enjoy it from every ride.



Disclaimer & Warning

During the cycling process, comprehensive safety measures should be taken, and risk awareness and good judgment should be maintained at all times to avoid injuries as much as possible.

- The user must be an adult.
- The responsibility for iENYRID maintenance is yours! Proper and frequent maintenance will reduce risks of injuries.
- Please wear a helmet, protective gear, and other safety measures when riding.
- Always follow local laws and regulations.
- Do not perform stunts, spins or jumps; if you insist on doing these dangerous actions, please take full protective measures.

CONTENT

Product & Component Display.....	1~2
Product Parameters	3
Products & Accessories	4
Product Installation	5~7
Product Folding	8
Power On & Unlock.....	9
Safe Driving Warning	10~11
Battery & Charging	12~13
Error Code	14
After Sales	15
Limited Warranty	16
Warranty Card	17

Product & Component Display

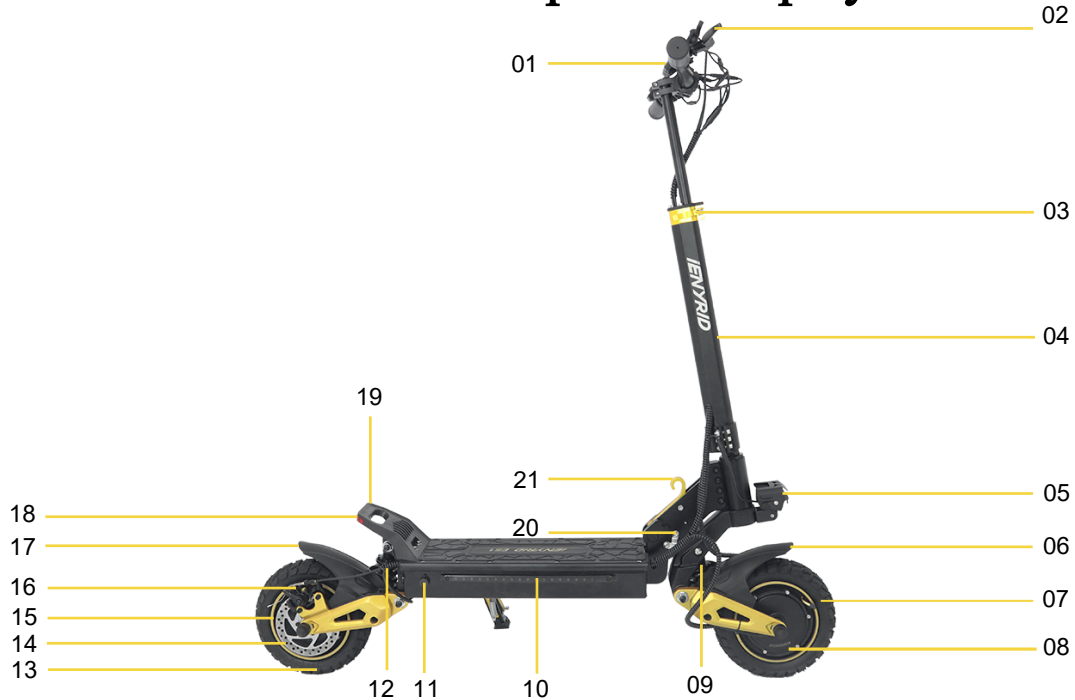

01: Instrument

02: Front brake lever

03: Vertical pole buckle

04: Vertical pole

05: Headlights

06: Front fender

07: Front wheel

08: Front motor

09: Front shock absorber

10: Side lights

11: Charging port

12: Rear shock absorber

13: Rear wheel

14: Rear brake pads

15: Rear motor

16: Rear disc brake

17: Rear fender

18: Brake lights

19: Lift handle

20: Safety latch

21: Folding button

Product & Component Display



01: Rear brake lever

02: Horn

03: Headlight switch

04: Power on button

05: Upshift key

06: Downshift key

07: Turn signal switch

08: Single/double motors button

09: Gear

10: Mileage

11: Gear number

12: Battery display

13: Voltage display

14: Real time speed display

15: Single/double motors display

16: Fault code display

17: Accelerator

18: Front brake lever

Product Parameters

Model	iE-ES1	Tire Size	10 inch
Battery	48V/20.8Ah	Tyre Type	Air tires
Power	250	Charging time	6~8 hours
Display Screen	Color	Frame Material	Aluminum alloy
Max Speed	20KM/H	Net Weight	30KG
Range	50-60KM	Gross Weight	34KG
Max Load	120KG	Package Size	128*24*48cm
Brake	Front and rear disc brake		
Light	Front LED headlights, side lights and tail lights		
Adapter	Output 54.6V 2A		

The weight of the tester is 80kg, and the range of the flat road test is 50-60km. The length of the range depends on the weight of the rider, the riding conditions, and the temperature; If the weight of the cyclist exceeds 80kg, the road conditions are rough, and the temperature is low, the range will be correspondingly shortened.

Products & Accessories

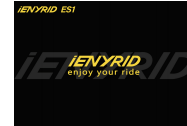

SERIAL NUMBER	ITEM	QUANTITY
1	Charger	1
2	Toolkit	1
3	Instructions	1

Product Installation

01 Remove the scooter from the packaging box



02 Unscrew the screws at the foot support installation location



03 Align the screw holes and insert the screws



04 Tighten the screw firmly



05 Press down on the folding lever and lift up the upright lever



06 After the pole is fully extended, snap the safety buckle into place



07 Remove the upright screw and cover plate



08 Place the handle into the upright pole



09 After adjusting the angle of the handle, tighten the fixing screws



10 Place the pole cover and screws into the pole and tighten the screws



11 Remove the instrument bracket from the bag and install the rubber pad



12 Place the rubber pad into the bracket of the instrument panel



13

Fix the instrument panel in the middle position of the handle and tighten the screws



14

Match the plug color and firmly insert it in the direction indicated by the arrow



15

Adjust the installation angle of the brake lever, button, and dashboard on the handlebars and tighten the screws



16

While pressing the limit button, pull the pole upwards until it reaches the appropriate position



17

Lock the upright pole buckle



18

Assembly completed



Product Folding

01 Release the buckle of the pole



02 Press down on the pole while pressing the limit point



03 Pull the safety lever backwards



04 Pull the folding lever backwards



05 Press down on the upright pole until you hear a clicking sound



06 Folding completed



Power On & Unlock

Long press the power button



to enter the password input interface



, press the

power button



three times to enter the three zero password



, and then quickly

press the power button



twice to unlock it



.

The unlocking process takes a short time, and it is normal for the screen to turn off if not unlocked within the specified time. This is to protect some people from stealing the scooter. If you encounter forgetting your password, please refer to the manual.

After unlocking, please wear a helmet and protective gear before cycling, and ensure that all functions of the scooter are normal before starting your cycling.

Safe Driving Warning

Certain countries of regions require safety devices or gear. It is your responsibility to know the state laws and follow them. However, we strongly recommend safety gears to be donned before operating the device.

TIRE AIR PRESSURE: THE TIRE IS PRESSURIZED TO THE STANDARD VALUE ON THE TIRE

SAFETY GEAR

Helmet: Most common and serious injuries from riding are head injuries. This can be prevented by donning a helmet. You must wear a helmet when riding the iENYRID Scooter. The helmet must be worn according to their instruction.

MECHANICAL SAFETY

Before using the iENYRID Scooter:

- 1) Always perform a visual inspection of all screws and nuts are tight and in place. If anything is amiss or missing and you are unsure, please contact the seller to confirm safety before use.
- 2) Check the tires and wheels and that it is not showing signs of wear and tear; Always ensure that the brake mechanism is not touching the wheels and allows free spinning.
- 3) Always perform mechanical checks of brakes and other parts of the scooter that allows visibility, safety and functionality of the scooter to be.

RIDING SAFETY

- 1) Put one foot on the board and the other on the ground.
- 2) Press the accelerator lever slightly, and the scooter accelerates. Put both feet on the board after you can keep balance. Press down the lever to speed the scooter up.
- 3) Release the accelerator to slow down. Squeeze the brake lever at the left handle bar to stop the scooter.
- 4) Tilt your body slightly to the side you want to turn, and slowly turn the handlebars.
- 5) Do not ride in the rain.
- 6) Please slow down before speed bumps, potholes and other uneven surfaces. Bend your knees to steady yourself on the complex road.
- 7) Do not accelerate downhill.
- 8) Do not hang heavy objects such as backpacks on the handlebars.
- 9) Do not press the accelerator when you walk on foot.
- 10) Do not ride on the roadways.
- 11) Do not turn suddenly at high speed.
- 12) No riding to water above 2cm.
- 13) No riding with another person or a child.
- 14) Do not step on the fender.
- 15) Do not touch the disk brake after braking frequently, it will be very hot!
- 16) Do not release the handlebars while riding!
- 17) No riding upstairs or downstairs!

Battery & Charging

BATTERY

- **Do not charge indoors.**
- Do not turn on and operate the scooter while charging.
- Keep the battery away from children, pets or direct heat.
- Do not expose the battery to high temperature and pressure.
- Please use the charger included with the scooter for charging.
- Please do not throw away batteries at will to avoid polluting the environment.
- Do not store the scooter over a long period of time with an almost empty battery.
- From time to time, discharge the battery by riding. Have the battery recharge again and make sure to not leave battery fully empty.

Do not charge if the scooter has the following conditions occur:

- The battery leaks.
- The battery is damaged.
- The battery heats up or is deformed.
- The bottom or overall of the deck overheats.

The use, storage or charging of the battery outside specified limits may result in the annulment of the warranty, battery damage and an effective battery charging.

Battery & Charging

First Charge

It is important to fully charge the battery before your first use of the scooter.

Your scooter's battery comes with these built-in features:

1. Balanced charging protection: During charging, the battery automatically balances the voltage among the internal cells to protect each cell.
2. Over-charging protection: The battery stops charging automatically when full to protect against damage.
3. Over current protection: The battery automatically stops charging if the voltage is higher than prescribed voltage to protect the battery.
4. Over discharging protection: The battery automatically stops discharging when its voltage drops below Under voltage value to protect the battery.
5. Short-circuit protection: the battery automatically stops output in the case of a short-circuit.

How to charge

1. Do not charge indoors.

2. Ensure that scooter is **TURNED OFF**. Connect external power charger to scooter.
3. Connect charger to electrical outlet, then turn on the power of electrical outlet.
4. Do not charge the batteries in temperatures below 5 °C or above 40 °C. The battery may stop the charging process.
5. The charger lights up RED- The battery is charging. The charger lights up GREEN – The battery is fully charged.
6. After the battery is fully charged, please unplug the charger in time.

Error Code

Error Code	Fault	Diagnostic Step	Solution
3E	Motor fault	Check whether the motor wires are connected properly or whether the colored wires are connected incorrectly.	If there is no problem with each circuit, the motor needs to be replaced.
4E	Low voltage protection	Check if the battery is used up.	The battery is dead and needs to be charged.
5E	Brake lever failure	After the system is powered on, check whether the brakes are working properly.	If the brake signal is less than 0.75V for a long period of time, the brake lever needs to be replaced.
6E	Motor Hall failure	Check whether the motor wires are connected properly or whether the colored wires are connected incorrectly.	If there is no problem with each circuit, the motor needs to be replaced.
7E	Accelerator failure	Check if the accelerator is reset.	After the accelerator is reset, if the handlebar signal is still less than 0.75V, the accelerator needs to be replaced.
8E	Controller failure	Controller failure	Replace controller
10E	Communication failure	The controller cannot receive the instrument signal. Check whether the yellow line of the controller is connected properly.	Replace meter
15E	Communication fail	The instrument cannot receive the signal from the controller. Check whether the green line of the controller is connected properly.	Replace controller

After Sales

Dear customer,

Thank you for choosing our product! To ensure that you can install and use our product smoothly, we strongly recommend that you visit our official website to view the related video installation tutorials and after-sales parts replacement videos.

On our official website, you can find detailed video tutorials that guide you on how to correctly install and use our product. In addition, we also provide after-sales parts replacement videos to ensure that you can correctly perform the replacement when needed.

We hope these videos will help you better understand and use our product. If you still have questions or concerns after watching the videos, please feel free to contact our customer service team, and we will be happy to assist you.

Thank you again for your purchase and support!

Wishing you a pleasant user experience!



<https://www.ienyrid.com>



<https://www.facebook.com/iENYRID>



<https://www.youtube.com/@iENYRID>

Limited Warranty

BY USING THIS PRODUCT YOU AGREE TO THIS LIMITED WARRANTY.

PLEASE READ THIS LIMITED WARRANTY CAREFULLY.

To benefit from the limited warranty, the customer is advised to read iENYRID Warranty terms together with the “care and maintenance” sections provided in the user manual. This limited warranty applies to the extent permitted by law and unless restricted or prohibited by law.

Attentions for warranty Faults caused by any of following causes are not within the scope of warranty:

1. Failed to maintain according to this user manual.
2. Product damage or defects caused by improper driver operation.
3. Damage caused by misuse, traffic accident or accidental collision.
4. Damage caused by riding on abnormal roads or accidental collision.
5. Damage of the vehicle caused by natural disaster or irresistible force.
6. Products which have had their serial numbers removed or tampered with.
7. Defects or malfunctions of the product not notified by customer during the Warranty Period.
8. Products used for commercial purposes including but not limited to leasing/hiring, use in competitions etc.
9. Performing high-risk actions such as stunts, spinning, or jumping lead to rapid aging or malfunction of the product.
10. Expose this product under blazing sun or outdoor for along time,as that will speed up the aging process of the product and cause malfunction.
11. Defects or damages from improper storage, exposure to moisture or dampness, modifications, connections, repairs (except as carried out by iENYRID or its authorised centres), misuse, neglect, abuse, accident, alteration, improper installation, or other acts which are not the fault of iENYRID , including damage caused by dropping, blown fuses, liquid entering the interior of the product.

Warranty Card

Dear user, Thanks for using our electric scooter. Please fill in the form below clearly for sake of better after-sale services.

User	Name		Workplace	
	Tel			
	Add			
Date of Purchase			Serial number	
Model			VIN	
Invoice Number			Battery serial number	
Distributor	Name			
	Contact			
Note				

Shenzhen Tianshengle Technology Co., Ltd.

 Address: Room 502, 5th Floor, Building 1, Liuwei Business Center, No.5, Longjing Community, Yangmei Community, Bantian Street, Longgang District, Shenzhen, China

 WhatsApp: +8613612953725

 Customer support: support@ienyrid.com

 Official website: www.ienyrid.com



iENYRID

enjoy your ride