

iENYRID iE-ES60

iENYRID

enjoy your ride

USER MANUAL

INNYRID

PLEASE READ THE INSTRUCTIONS CAREFULLY BEFORE RIDING



Scan QR Code Or Enter URL for Online Installation

<https://www.youtube.com/watch?v=zkcq1U3Hdg8>



Read This Manual Before Using

Why Is It Necessary To Read This Manual Before Operating?

- 1、 This manual was written to help you understand the proper use and maintenance of the iENYRID line of Electric Scooter.
- 2、 It is important to understand the functions and features of the new iENYRID before operating it as it will allow you to enjoy it from every ride.



Disclaimer & Warning

During the cycling process, comprehensive safety measures should be taken, and risk awareness and good judgment should be maintained at all times to avoid injuries as much as possible.

- The responsibility for iENYRID maintenance is yours! Proper and frequent maintenance will reduce risks of injuries.
- Please wear a helmet, protective gear, and other safety measures when riding.
- Always follow local laws and regulations.
- Do not perform stunts, spins or jumps; if you insist on doing these dangerous actions, please take full protective measures.

CONTENT

Product & Component Display	1~2
Product Parameters	3
Products & Accessories	4
Product Installation	5~6
Product Folding	7
Power On & Unlock & Combination Lock.....	8
Safe Driving Warning	9
Battery & Charging	10~11
Error Code	12
After Sales	13
Limited Warranty	14
Warranty Card	15

Product & Component Display

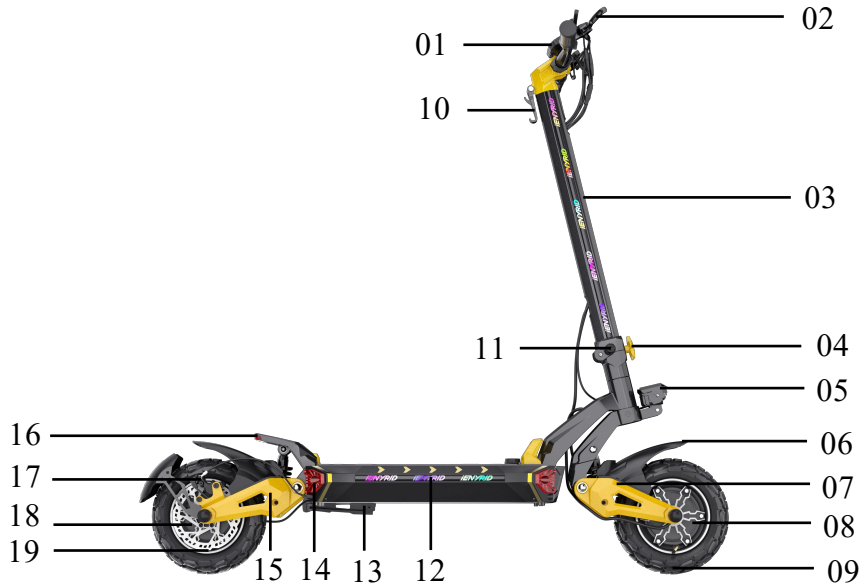

01: Instrument

02: Brake lever

03: Vertical pole

04: Folding buckle

05: Headlights

06: Front fender

07: Front shock absorber

08: Fron motor

09: Front wheel

10: Folding hook

11: Plug

12: Side light strip

13: Kickstand

14: Turn signal

15: Rear shock absorber

16: Tail lights

17: Rear brake

18: Rear motor

19: Brake pads

Product & Component Display

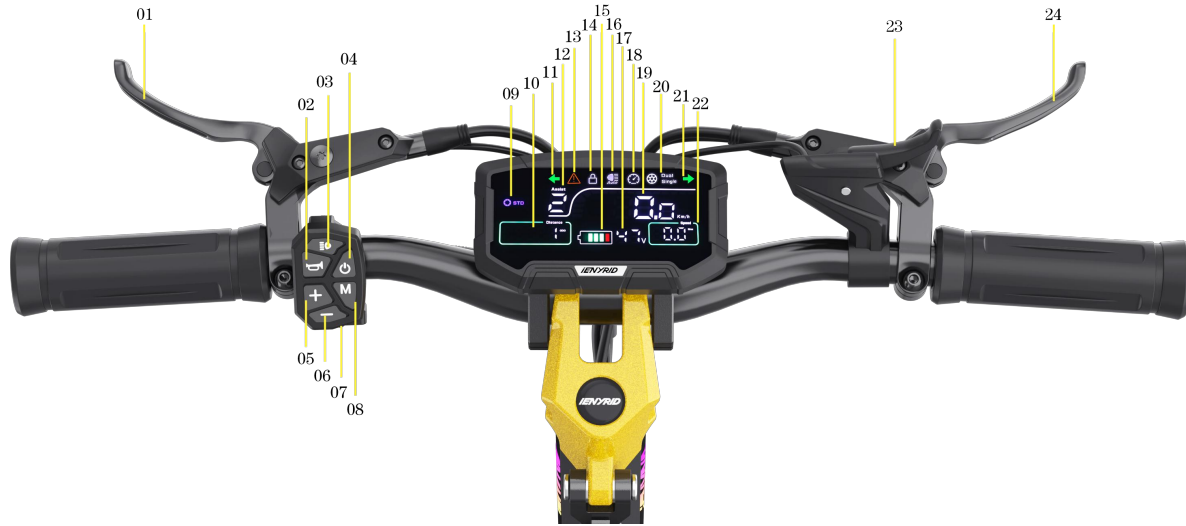

01: Rear brake lever
02: Horn
03: Headlight switch
04: Power on button
05: Upshift key
06: Downshift key
07: Turn signal switch
08: Menu button

09: Gear
10: Mileage
11: Left turn signal lamp
12: Gear number
13: Brake signal/Fault
14: Lock the car
15: Battery display
16: Lamp

17: Voltage display
18: Cruise control
19: Real time speed
20: Single/double motors
21: Right turn signal lamp
22: Fault code display
23: Accelerator
24: Front brake lever

Product Parameters

Model	iE-ES60	Tire Size	11 inch
Battery	48V/23Ah	Tyre Type	Off-road Air tires
Power	1200*2	Charging time	Single charger: 8-10 hours Dual charger: 4-6 hours
Display Screen	Color	Frame Material	Aluminum alloy
Max Speed	25-60KM/H	Net Weight	39.6KG
Range	55-70KM	Gross Weight	49KG
Max Load	150KG	Package Size	137*34*60cm
Break	Electronic power-off brakes + Front and rear hydraulic disc brakes		
Shock absorption	Front and rear hydraulic double wishbone suspension		
Light	Integrated headlight (with built-in horn), pole and frame side fantasy color lights, front and rear turn signals, eagle-eye spotlight, rear running light, and brake light.		
Adapter	Input 100-240 V~50/60Hz 2.5A, Output 54.6 V 2.0A		
Maximum load and speed may vary depending on the rider's weight, riding style and terrain.			

Products & Accessories



SERIAL NUMBER	ITEM	QUANTITY
1	Electric Scooter	1
2	Charger	1
3	Instructions	1
4	Toolkit	1

Product Installation

1

Remove the scooter from the packaging box



2

Lift the scooter's folding stem upright



3

Secure the folding latch



4

Ensure that the folding buckle is securely locked, which is a prerequisite for safe driving



5

Adjust the handlebar stem to the correct position



6

Align the screw holes

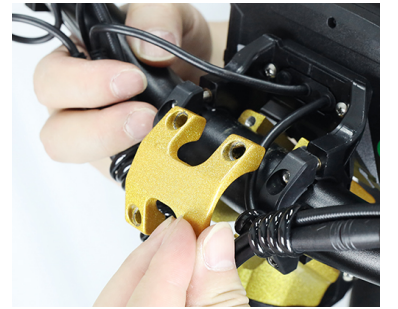

7

Tighten the handlebar stem screws

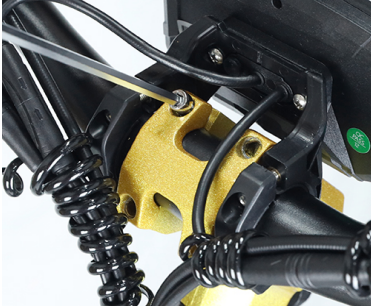

8

Ensure all four screws on the handlebar stem are firmly tightened

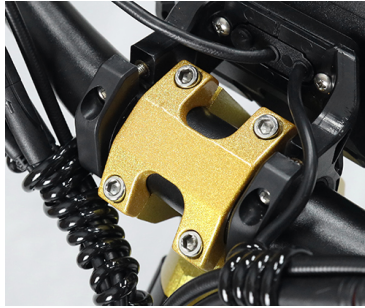

9

Assembly completed



Product Folding

1 Unscrew the folding latch



2 Pull out the pin



3 Lower the scooter's folding stem



4 Locate the slot corresponding to the latch









5 Secure the latch



6 Folding



Power On & Unlock & Combination Lock

Long press the power button  to enter the password input interface  , press the power button  three times to enter the three zero password  , and then quickly press the power button  twice to unlock it  .

The unlocking process takes a short time, and it is normal for the screen to turn off if not unlocked within the specified time. This is to protect some people from stealing the scooter. If you encounter forgetting your password, please refer to the manual.

After unlocking, please wear a helmet and protective gear before cycling, and ensure that all functions of the scooter are normal before starting your cycling.

- Unlock the Battery with Original Password:
<https://www.youtube.com/watch?v=hb6DROovJCw>
- Change the Password of Battery:
<https://www.youtube.com/watch?v=zEp9xpuU1yA>

The factory password for the new car is: 000.

Adjust all passwords to 000 and turn them to the left.

How to change the password: There is a password change hole at the bottom of the lock. When it is open, use a small stick to top this hole and do not loosen it, Then change the password, release it after completion, and the password change is complete. Just shuffle the password after locking.

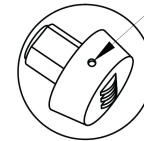

Combination Lock

Safe Driving Warning

Certain countries of regions require safety devices or gear. It is your responsibility to know the state laws and follow them. However, we strongly recommend safety gears to be donned before operating the device.

TIRE AIR PRESSURE: THE TIRE IS PRESSURIZED TO THE STANDARD VALUE ON THE TIRE

SAFETY GEAR

Helmet: Most common and serious injuries from riding are head injuries. This can be prevented by donning a helmet. You must wear a helmet when riding the iENYRID Scooter. The helmet must be worn according to their instruction.

MECHANICAL SAFETY

Before using the iENYRID Scooter:

- 1) Always perform a visual inspection of all screws and nuts are tight and in place. If anything is amiss or missing and you are unsure, please contact the seller to confirm safety before use.
- 2) Check the tires and wheels and that it is not showing signs of wear and tear; Always ensure that the brake mechanism is not touching the wheels and allows free spinning.
- 3) Always perform mechanical checks of brakes and other parts of the scooter that allows visibility, safety and functionality of the scooter to be.

Battery & Charging

BATTERY

- **Do not charge indoors.**
- Do not turn on and operate the scooter while charging.
- Keep the battery away from children, pets or direct heat.
- Do not expose the battery to high temperature and pressure.
- Please use the charger included with the scooter for charging.
- Please do not throw away batteries at will to avoid polluting the environment.
- Do not store the scooter over a long period of time with an almost empty battery.
- From time to time, discharge the battery by riding. Have the battery recharge again and make sure to not leave battery fully empty.

Do not charge if the scooter has the following conditions occur:

- The battery leaks.
- The battery is damaged.
- The battery heats up or is deformed.
- The bottom or overall of the deck overheats.

The use, storage or charging of the battery outside specified limits may result in the annulment of the warranty, battery damage and an effective battery charging.

Battery & Charging

First Charge

It is important to fully charge the battery before your first use of the scooter.

Your scooter's battery comes with these built-in features:

1. Balanced charging protection: During charging, the battery automatically balances the voltage among the internal cells to protect each cell.
2. Over-charging protection: The battery stops charging automatically when full to protect against damage.
3. Over current protection: The battery automatically stops charging if the voltage is higher than prescribed voltage to protect the battery.
4. Over discharging protection: The battery automatically stops discharging when its voltage drops below Under voltage value to protect the battery.
5. Short-circuit protection: the battery automatically stops output in the case of a short-circuit.

How to charge

- 1. Do not charge indoors.**
2. Ensure that scooter is **TURNED OFF**. Connect external power charger to scooter.
3. Connect charger to electrical outlet, then turn on the power of electrical outlet.
4. Do not charge the batteries in temperatures below 5 °C or above 40 °C. The battery may stop the charging process.
5. The charger lights up RED- The battery is charging. The charger lights up GREEN – The battery is fully charged.
6. After the battery is fully charged, please unplug the charger in time.

Error Code

Error Code	Fault	Diagnostic Step	Solution
3E	Phase fault	Check whether the motor wires are connected properly or whether the colored wires are connected incorrectly.	If there is no problem with each circuit, the motor needs to be replaced.
4E	Low voltage protection	Check if the battery is used up.	The battery is dead and needs to be charged.
5E	Brake lever failure	After the system is powered on, check whether the brakes are working properly.	If the brake signal is less than 0.75V for a long period of time, the brake lever needs to be replaced.
6E	Motor Hall failure	Check whether the motor wires are connected properly or whether the colored wires are connected incorrectly.	If there is no problem with each circuit, the motor needs to be replaced.
7E	Accelerator failure	Check if the accelerator is reset.	After the accelerator is reset, if the handlebar signal is still less than 0.75V, the accelerator needs to be replaced.
8E	Controller failure	Controller failure	Replace controller
10E	Communication failure	The controller cannot receive the instrument signal. Check whether the yellow line of the controller is connected properly.	Replace meter
15E	Communication fail	The instrument cannot receive the signal from the controller. Check whether the green line of the controller is connected properly.	Replace controller

After Sales

Dear customer,

Thank you for choosing our product! To ensure that you can install and use our product smoothly, we strongly recommend that you visit our official website to view the related video installation tutorials and after-sales parts replacement videos.

On our official website, you can find detailed video tutorials that guide you on how to correctly install and use our product. In addition, we also provide after-sales parts replacement videos to ensure that you can correctly perform the replacement when needed.

We hope these videos will help you better understand and use our product. If you still have questions or concerns after watching the videos, please feel free to contact our customer service team, and we will be happy to assist you.

Thank you again for your purchase and support!

Wishing you a pleasant user experience!



<https://www.ienyrid.com>



<https://www.facebook.com/iENYRID>



<https://www.youtube.com/@iENYRID>

Limited Warranty

BY USING THIS PRODUCT YOU AGREE TO THIS LIMITED WARRANTY.
PLEASE READ THIS LIMITED WARRANTY CAREFULLY.

To benefit from the limited warranty, the customer is advised to read iENYRID Warranty terms together with the “care and maintenance” sections provided in the user manual. This limited warranty applies to the extent permitted by law and unless restricted or prohibited by law.

Attentions for warranty Faults caused by any of following causes are not within the scope of warranty:

1. Failed to maintain according to this user manual.
2. Product damage or defects caused by improper driver operation.
3. Damage caused by misuse, traffic accident or accidental collision.
4. Damage caused by riding on abnormal roads or accidental collision.
5. Damage of the vehicle caused by natural disaster or irresistible force.
6. Products which have had their serial numbers removed or tampered with.
7. Defects or malfunctions of the product not notified by customer during the Warranty Period.
8. Products used for commercial purposes including but not limited to leasing/hiring, use in competitions etc.
9. Performing high-risk actions such as stunts, spinning, or jumping lead to rapid aging or malfunction of the product.
10. Expose this product under blazing sun or outdoor for along time, as that will speed up the aging process of the product and cause malfunction.
11. Defects or damages from improper storage, exposure to moisture or dampness, modifications, connections, repairs (except as carried out by iENYRID or its authorised centres), misuse, neglect, abuse, accident, alteration, improper installation, or other acts which are not the fault of iENYRID, including damage caused by dropping, blown fuses, liquid entering the interior of the product.

PLEASE ALWAYS KEEP THE BOX FOR ANY POSSIBLE FUTURE AFTER-SALES SHIPMENT

Warranty Card

Dear user, Thanks for using our electric scooter. Please fill in the form below clearly for sake of better after-sale services.

User	Name		Workplace	
	Tel			
	Add			
Date of Purchase			Serial number	
Model			VIN	
Invoice Number			Battery serial number	
Distributor	Name			
	Contact			
Note				

Shenzhen Tianshengle Technology Co., Ltd.

 Address: Room 502, 5th Floor, Building 1, Liuwei Business Center, No. 5, Longjing Community, Yangmei Community, Bantian Street, Longgang District, Shenzhen, China

 WhatsApp: +8613612953725

 Customer support: support@ienyrid.com

 Official website: www.ienyrid.com



iENVYRID

enjoy your ride